



Model Helicopter Insights TM **RC Helicopter Primer**

Wolf Witt

October 26, 2009

Revision 3.0-A

Copyright © 2006-2009 Wolf Witt
All Rights Reserved

Photographic images (e.g. product photos) acquired from the world wide web unless otherwise noted. All text, tables, drawings diagrams, simulator screen captures and document scans by Wolf Witt unless otherwise noted.

The right to reproduce this material for non-commercial purposes is hereby granted, provided it is reproduced in unedited form, in its entirety, with all credit and copyright notices intact. This material may not be used for commercial purposes without express written permission from the author.

RC Helicopter Primer

Your Introduction to RC Helicopters



Model Helicopter Insights™
RC Helicopter Primer

- Answers to Frequently Asked Questions
- Structure of a Helicopter
- Helicopter Operation
- Model Helicopter Control
- Helicopter Kits and Components
- Tips to Get Started



Photos by E. Ryu



RC Helicopter Primer

Introduction

RC Helicopter Primer

About the Author



Model Helicopter Insights™
RC Helicopter Primer

I became interested in RC helicopters when I was 10 years old and finally got around to starting the hobby in 2004 at age 37. Now I fly mostly on Sundays at the Bayside RC Club in Fremont, California.

I'm not claiming to be an exceptional pilot or know everything, but since 2004 I've learned a lot about how helicopters work. For my day job, I work as an engineer at a major semiconductor company, and with my engineer's mentality, I enjoy the physics, mechanics and electronics associated with RC helicopters as much as flying the models.

I remember, however, that I had a steep learning curve to get to this level of knowledge, so I wanted to do something to make this great hobby more accessible to others. This presentation is the first result, and if you're interested in RC helicopters, I hope this material will help you get started.

*I'd like to thank the friendly and knowledgeable pilots at the Bayside RC Club who helped me with my first helicopter and still help me today. Also many thanks to the authors of other introductory guides and assorted educational posts in on-line discussion forums. Other guides (such as the *Electric Helicopter Beginner's Guide* or *EHBG** by Toshiyasu Morita) may be good complements to this primer.*

Happy flying and be safe!

*-- Wolf Witt
rcwolf@ymail.com*

** See *Additional Resources* at the end of this primer.*

RC Helicopter Primer

Motivation for this Primer (1)



Model Helicopter Insights™
RC Helicopter Primer

- Building and flying radio controlled (RC) model helicopters is an enjoyable, multi-faceted, challenging, rewarding hobby. 
- RC helicopters are not toys;* they are sophisticated machines that require the hobbyist and pilot to have...
 - some technical aptitude to build and set up his or her helicopter.
 - a sense of responsibility to operate helicopters safely.
 - the skill to fly helicopters successfully (or the patience to learn that skill).
- After a pilot acquires one skill...
 - exercising that skill feels very satisfying.
 - there are always more skills that he or she can aim to master.
- The RC helicopter hobby has many aspects, providing a variety of challenges in addition to flying.
- RC helicopter technology also continues to evolve, offering upgrade paths and new capabilities.



* Ok, maybe they are toys, but they're *serious* toys. 😊

RC Helicopter Primer

Motivation for this Primer (2)



Model Helicopter Insights™
RC Helicopter Primer

- Getting started with radio controlled (RC) helicopters can be a confusing and daunting undertaking.  
- Many types and brands of model helicopters exist.
- Most helicopters require that the pilot chooses, purchases, assembles and tunes multiple components.
- Helicopters are intricate machines, and most instruction manuals leave something to be desired, so getting a helicopter to fly well can be tricky.
- Some reference books, videos and web sites are available, but even the good ones often assume that the reader has base knowledge that he or she may not have.
- Other helicopter pilots are almost always ready to help but...
 - while most of them know what they're talking about, a few do not.
 - the ones who know are not always able to explain themselves clearly.
 - you may get multiple, different (and possibly correct) answers to one question.
 - the line between facts and opinions is often blurry.

RC Helicopter Primer

Objectives



Model Helicopter Insights™
RC Helicopter Primer

- Provide new, prospective RC helicopter pilots like you with a more solid starting point.
 - Give you an overview of the landscape of RC helicopters.
 - RC helicopter terminology
 - Helicopter operation
 - Types of helicopters and their major components
 - Items that are needed to build them
 - Help you decide whether to take the plunge into this fun and interesting hobby.
 - Allow you to ask more focused questions in the future, so you can learn even more.
 - Enable you to understand different RC helicopter-related tradeoffs.
 - Empower you to make more informed purchasing decisions.
 - Prepare you for some experiences you should expect in this endeavor.
- Increase the likelihood that you will...
 - successfully climb the sometimes steep initial learning curve.
 - enjoy this great hobby.



RC Helicopter Primer

Non-Objectives (i.e. stuff this presentation does not cover)



Model Helicopter Insights™
RC Helicopter Primer

- Make specific purchasing recommendations.
- Answer “which is better” questions.
 - Which helicopter or component is best almost always depends on the circumstances.
 - People’s answers to the “which is better” question are often based more on opinion than objective comparisons.
 - What’s good at any given time changes as new products are introduced.
- Teach the details of how to build a new helicopter.*
- Teach how to set up a helicopter and transmitter.*
- Teach how to fly.*

- For the first two, readers should make up their own minds.
- The last three are beyond the scope of this presentation.*

* Although there are some tips near the end, in the *Tips to Get Started* section.

RC Helicopter Primer

Corollary to Non-Objectives

- The following slides will show pictures of various helicopters, helicopter components and accessories as examples, but...
- A goal of this slide set is not to focus on any particular brands or makes but to provide a representative cross-section of what exists.*
- The intent of these slides is not to recommend any particular set of products.
- Everyone should always strive to make fully informed purchasing decisions.
- These slides aim to provide knowledge that will help enable such informed decisions.

* What exists at the time of this writing. RC helicopter technology and offerings change continually.

RC Helicopter Primer

Outline



Model Helicopter Insights™
RC Helicopter Primer

- Aspects of the RC Helicopter Hobby
- Answers to Frequently Asked Questions
- Helicopter Overview
 - Basic Structure of a Helicopter, Part 1
 - Basic Model Helicopter Control
 - Basic Principles of Helicopter Operation
 - Basic Structure of a Helicopter, Part 2
 - Overview of RC Helicopter Components
- RC Helicopter Component Details
 - Power Systems (Engines, Motors)
 - Servos
 - Helicopter Kits
 - Gyros
 - Governors
 - Automatic Mixture Controllers
 - Transmitters and Receivers
 - BECs / Voltage Regulators
 - Multi-Function Modules
 - Tools and Equipment
- Tips to Get Started
 - Helicopter Selection
 - Helicopter Assembly
 - Helicopter Setup and Checkout
 - First Flights
 - Simulator Practice

RC Helicopter Primer

Abandon All Hope Yee Who Enter?



Model Helicopter Insights™
RC Helicopter Primer

- The following slides contain *a lot* of information.
- Many new terms and concepts will be introduced (and this presentation is only the beginning).
- Ask questions, so things make sense to you.
- In any case, you will most likely not remember everything.
- Don't worry; not remembering it all is ok.
- By reading and seeing something here once, it will make more sense later, when you encounter it again.
- You can use this material as a reference, and go back to focus on items most relevant to you.

RC Helicopter Primer

Aspects of the RC Helicopter Hobby

Answers to Frequently Asked Questions

...or why you want to take up this cool hobby...



RC Helicopter Primer

Aspects of the Hobby (1)



Model Helicopter Insights™
RC Helicopter Primer

- Choosing a kit and components for a model (or “shopping for people who otherwise may not like to shop” 😊).
 - Many options exist for different desires (e.g. types of flight) and constraints (e.g. budget, flying area).
 - In most helicopters, components may be upgraded over time to improve the models’ flight characteristics (or just make them look better).
- Building the model.
 - Some starter helicopters come partially or almost fully assembled.
 - *ARF*: almost ready to fly
 - *RTF*: ready to fly
 - Most models need to be built from numerous individual parts.
 - The basic kit needs to be assembled.
 - The engine or motor as well as the electronics need to be installed.
 - Once built, a model’s mechanisms need to be adjusted and tuned carefully to achieve smooth flight characteristics.

RC Helicopter Primer

Aspects of the Hobby (2)

- Wiring up the aviation electronics or *avionics*.
 - All RC helicopters include some electronics, such as a radio receiver.
 - Especially for electric helicopters...
 - an understanding of basic electrical theory comes in handy.
 - some soldering work may be required.
- Programming the radio control transmitter.
 - Most of today's transmitters are very flexible, computer-based radios.
 - The transmitter needs to be configured to control the model for basic and advanced flight modes.
- Tuning the power system (for fuel as well as electric power).
 - The power system should be efficient and deliver maximum power to the rotor.
 - The engine or motor must be set up properly (e.g. so it doesn't run too hot) to provide reliable performance and long component lifetime.

RC Helicopter Primer

Aspects of the Hobby (3)

- Flying, of course!
 - Hovering
 - Forward flight and turns
 - Loops, rolls, flips; inverted and backward flight
 - Fancy stunt or 3D flight maneuvers
- Ongoing maintenance: tweaking, tuning and repairing.
 - Some parts will wear out over time and will need to be serviced or replaced for the helicopter to continue to fly and do so safely.
 - Sometimes something just doesn't work right, and the challenge will be to find the cause and correct the problem.
 - After a crash, the model will need to be repaired.
 - As the pilot's skills increase, adjustments to the model can make it a more capable machine.
- Shooting the breeze with other helicopter pilots. 😊

Answers to Frequently Asked Questions (1)

- How high or far can RC helicopters fly?
- *Assuming a properly functioning radio system, the practical limit is not the helicopter or the range of the radio link but the pilot's ability to see and keep track of the aircraft. The radio link will typically work for one to two miles (line of sight).*
- How long does one RC helicopter flight last?
- *Depending on the size of the helicopter, the choice of power system and the flying style (e.g. calm sport flying or aggressive aerobatics) flight times tend to range from 5 to 20 minutes per battery charge or fuel tank. In most cases, flights are in the neighborhood of 8 minutes.*
- How much does it cost to get started with RC helicopters?
- *An RC helicopter and associated equipment can total anywhere from \$200 to several thousands of dollars. To get started with anything other than a basic micro helicopter will cost in the neighborhood of \$1000 (possibly a bit less, easily more). Ready-to-fly electric micro-helicopter kits may be had for \$200 to \$300 (but may not be good starter machines).*

Answers to Frequently Asked Questions (2)

- Are helicopters more difficult to fly than airplanes?
- *Most people would say yes. While a flying airplane will tend to keep on flying, helicopters are inherently unstable and require constant control inputs. Both require skill to fly, and flying either is harder than it looks, but the initial learning curve for a helicopter may be a bit steeper.*
- Should one learn to fly airplanes before trying helicopters?
- *No. Knowing how to fly an RC airplane helps but is not required. Many people start directly with RC helicopters.*
- Can a new pilot learn to fly by him or herself?
- *Yes, but the experience is often more enjoyable with expert help. Many people initially underestimate the difficulty of setting up and flying an RC aircraft, such that the first flight often leads to a crash in only a few seconds. If at all possible, new pilots should seek help from experienced pilots.*

Answers to Frequently Asked Questions (3)

- How long does it take to learn to fly?
- *How much time a new pilot needs to become proficient varies greatly and depends on many factors, such as the pilot's talent and discipline as well as the amount time he or she can commit. Given those factors, some people may learn the basics (e.g. hovering, basic forward flight) in a few weeks or months while others may need a year to two.*
- What's the best way to learn to fly?
- *There is no method that works best for everybody. Some people learn by themselves by systematically taking one step after the other. Alternatively, flying clubs typically offer formal instruction through a buddy-box setup (two controllers connected together, so that the instructor can take control when needed). Either way, RC flight simulators that run on personal computers have become virtually indispensable tools, as they allow pilots to develop new skills without risking crashes of real models. The cost of a good simulator is usually more than recovered in money and time not spent on crash repairs.*

Answers to Frequently Asked Questions (4)

- What is “3D” flying?
- *The 3D term comes from the airplane world, where it describes aerobatics or stunt flights during which a plane is flying without using its wings to generate lift. Instead, it is staying airborne purely through the thrust generated by its engine. For helicopters, the 3D label is used very inconsistently. Better terms may be aggressive aerobatics or extreme aerobatics. One helicopter-focused definition of 3D is* “any maneuver that to be performed requires the constant harmonized input of three or more controls simultaneously while the maneuver is taking place.” Someone new to RC helicopters shouldn’t worry about 3D maneuvers for some time.*
- What type of RC helicopter might be a good choice for a beginner?
- *Opinions vary, but most would agree that a starter helicopter for someone who is serious about the hobby should be a collective pitch machine with a rotor diameter of about 700mm to 1350mm (i.e. something with 300mm to 600mm long main rotor blades). Smaller machines may not fly well or may get boring relatively quickly. Larger helicopters tend to be significantly more expensive and are not well suited for someone trying to learn the basics. Regardless of the actual helicopter, an RC flight simulator should come first. A new pilot should spend several hours on a simulator before attempting to fly a real model.*

* Quoting Augusto; see <http://www.runryder.com/helicopter/t6270p1/>.

Answers to Frequently Asked Questions (5)

- Should a newcomer assemble his or her first helicopter from a kit or buy a pre-built model?
- *A pre-built model can get a new pilot into the air faster, but most would advise new pilots to assemble their own models.*
 - *First, there is no guarantee that the builder assembled and set up the helicopter correctly.*
 - *Second, by building a helicopter himself or herself, a new pilot will acquire a lot of valuable knowledge about how the helicopter functions.*
 - *Third, after the first crash, the helicopter will need to be repaired, and building experience is very beneficial at that point.*
 - *Building a helicopter, however, can be a challenging (and sometimes frustrating) undertaking, but a good instruction manual, books about RC helicopters, on-line resources and support from experienced pilots make it possible.*
 - *Pre-built or not, if at all possible have an experienced pilot check out your model before its first flight.*

Answers to Frequently Asked Questions (6)

- Are RC helicopter models difficult to build and set up?
- *The process of getting a model helicopter ready to fly consists of two major phases. First is the assembly of the model. The manuals that come with helicopter kits usually do a decent job of guiding the assembly process, but the quality of manuals varies. Furthermore, some part of a kit may not fit quite right, such that a little ingenuity may be required to complete the assembly. Second, the helicopter must be set up. Setup includes steps like tuning the rotor head mechanics, programming the radio transmitter and tuning the engine. The manuals supplied with helicopter kits usually do not cover the setup phase well. Ideally, an experienced builder and pilot is available for consultation (e.g. at the local RC model club). A perfectly good helicopter may not fly well or at all if it is not set up correctly, and new pilots often become discouraged when their machines don't work as expected.*

Answers to Frequently Asked Questions (7)

- What happens if a helicopter's engine quits in flight?
- *A helicopter cannot glide like a plane can. After loss of engine power, a pilot can, however, perform a maneuver called an auto-rotation through which a helicopter can still descend and land in a controlled fashion. Many pilots perform auto-rotations frequently for fun. (Small helicopters do not auto-rotate well. To allow for relatively good auto-rotations, a model helicopter should be large enough to use at least 500mm main rotor blades. See the discussion on helicopter sizes in the Helicopter Kits section.)*
- What are the chances of a crash and what happens after that?
- *Pilots can help avoid crashes by taking good care of their helicopters and first practicing new maneuvers on simulators. Every aircraft may nevertheless crash at some point due to pilot error or a mechanical or electrical failure. After a crash, a helicopter can most often be repaired to be as good as new.*

Answers to Frequently Asked Questions (8)

- Are helicopters dangerous?
- *RC helicopters (and planes) are not simple toys. Regardless of a helicopter's size, its rotor blades will spin at high speed – the tips of the main blades move at speeds in the range of 20% to 40% of the speed of sound or 150 to 300 miles per hour – and human contact with a spinning rotor can cause severe bruises, cuts or potentially more serious injuries. Pilots regularly need to inspect and maintain their models and need to follow safety procedures to minimize the risk of injury or property damage.*
- Is a license required to fly RC aircraft?
- *No, at least in the US, anybody can buy and fly an RC aircraft. However, most RC aircraft clubs will require membership in the Academy of Model Aeronautics (AMA). Among other things, the AMA provides some liability insurance in case a model causes property damage or injury.*

RC Helicopter Primer

Helicopter Overview

Basic Structure of a Helicopter, Part 1
Basic Model Helicopter Control
Basic Principles of Helicopter Operation
Basic Structure of a Helicopter, Part 2
Overview of RC Helicopter Components



RC Helicopter Primer

Helicopter Overview

Basic Structure of a Helicopter, Part 1

Basic Model Helicopter Control

Basic Principles of Helicopter Operation

Basic Structure of a Helicopter, Part 2

Overview of RC Helicopter Components

Helicopter Overview

Basic Structure of a Helicopter, Part 1



Model Helicopter Insights™
RC Helicopter Primer

- In terms of their appearance, two types of model helicopters exist:
 - *Pod-and-boom* helicopters: little more than the mechanics and electronics needed to fly.
 - *Scale* helicopters: nice looking bodies or fuselages wrapped around pod-and-boom (or sometimes custom-built) mechanisms to give the appearance of full-size helicopters.
- These slides focus on the basic, pod-and-boom structure because it is...
 - the most common.
 - the foundation for many scale helicopters.



Above: Impala helicopter model from RealFlight G3 simulator



Above: Bell Jet Ranger helicopter from RealFlight G3 simulator

Helicopter Overview

Basic Structure of a Helicopter, Part 1



Model Helicopter Insights™
RC Helicopter Primer

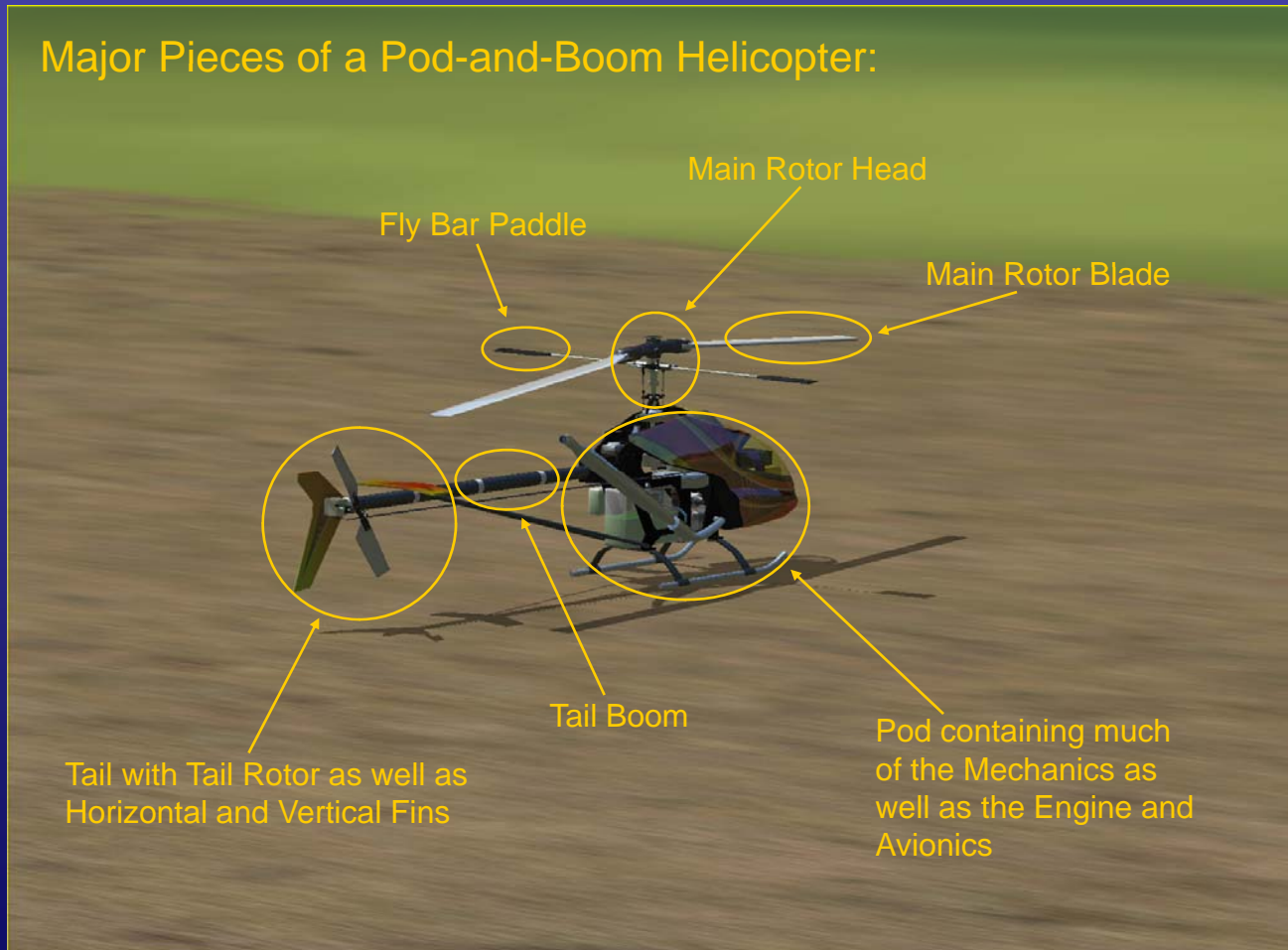

Above: Impala helicopter model from RealFlight G3 simulator



RC Helicopter Primer

Helicopter Overview

Basic Structure of a Helicopter, Part 1
Basic Model Helicopter Control
Basic Principles of Helicopter Operation
Basic Structure of a Helicopter, Part 2
Overview of RC Helicopter Components

Helicopter Overview: Basic Model Helicopter Control

- Model aircraft are controlled through radio transmitters like the ones on the right.
- During flight, the aircraft is steered using the left and right sticks.
- For now, ignore all of the other switches, buttons and dials on these transmitters.



Above: HiTec Eclipse 7 radio control transmitter (72MHz)

Below: Futaba 7C FASST radio control transmitter (2.4GHz spread spectrum)



Helicopter Overview

Model Control: Collective, Rudder

- Moving the left stick up^① or down^② makes the helicopter climb or descend.
- This control is the *collective pitch* and *throttle* control.
- Moving the left stick right^③ or left^④ makes the helicopter turn nose-right or nose-left (clockwise or counter-clockwise).
- This control is the *rudder* control.

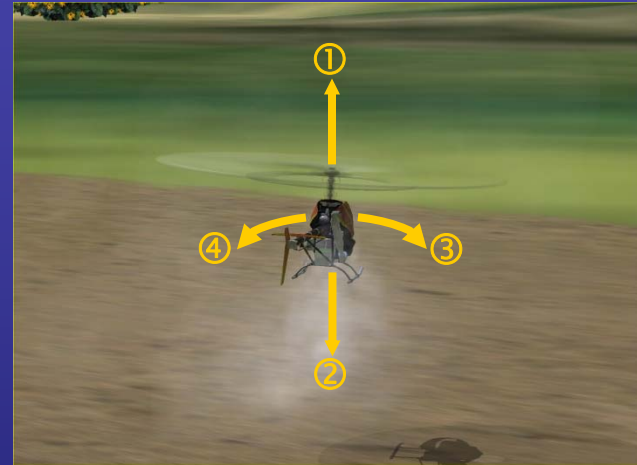

Above: Impala helicopter model from RealFlight G3 simulator



Above: Futaba 7C radio control transmitter

Helicopter Overview

Model Control: Elevator, Aileron

- Moving the right stick up^⑤ or down^⑥ makes the helicopter move (or roll) forward or backward.
- This control is the *elevator* or *fore/aft cyclic pitch* control.
- Moving the right stick right^⑦ or left^⑧ makes the helicopter move (or roll) right or left.
- This control is the *aileron* or *right/left cyclic pitch* control.



Above: Impala helicopter model from RealFlight G3 simulator



Above: Futaba 7C radio control transmitter



Helicopter Overview

Model Control: Axes of Rotation

- Helicopters (and airplanes) have three axes of rotation, corresponding to the controls.
- Changes in a control cause rotation around the associated axis.
- *Pitch** axis (elevator)
- *Roll* axis (aileron)
- *Yaw* axis (rudder)

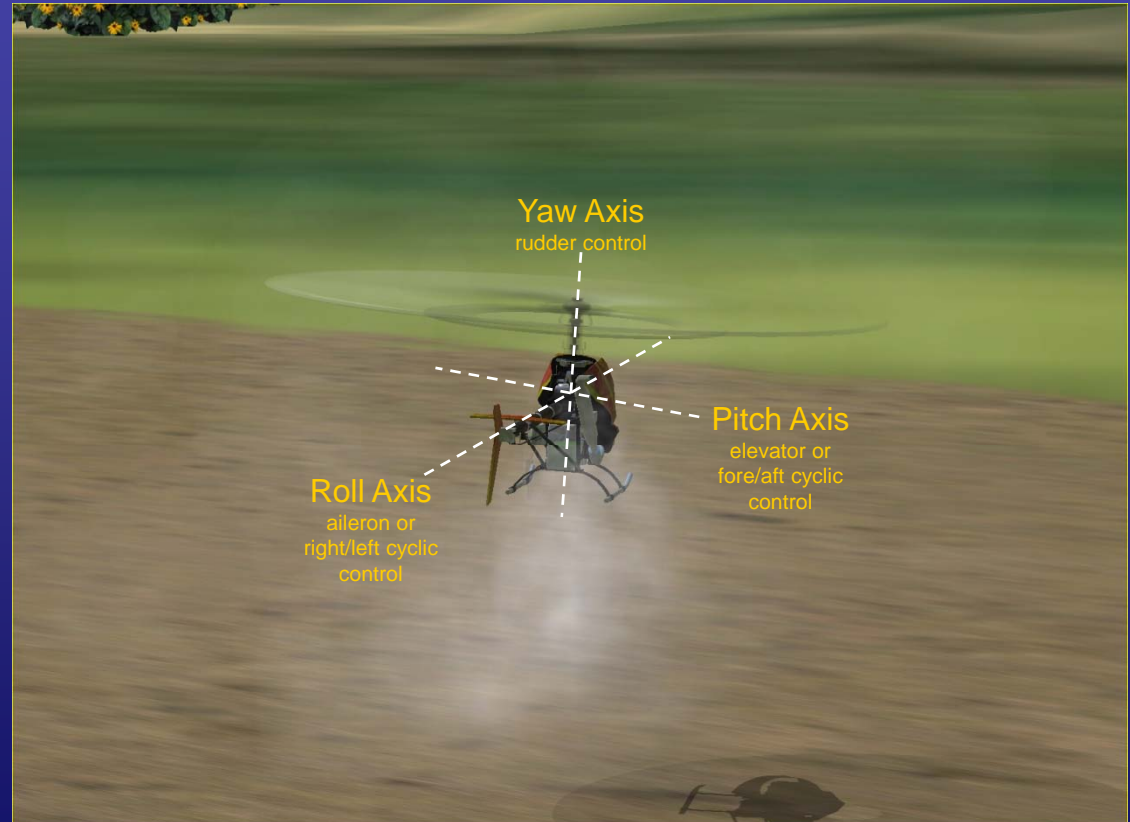

Above: Impala helicopter model from RealFlight G3 simulator

* Note that RC helicopter terminology uses the word “pitch” in multiple, different contexts and with different meanings, such as “collective pitch” and “pitch axis.”

Helicopter Overview

Model Control: Transmitter Modes



Model Helicopter Insights™
RC Helicopter Primer

- The previous slides described the operating convention of radio control transmitters in the US.
- The US mode of operation is known as *Mode 2*.
- In some other countries, transmitters are of the *Mode 1* type.
- Some transmitters may be switched to operate in either of the two modes.
- The two modes compare as shown below.



Above: Futaba 7C radio control transmitter

	Left Stick		Right Stick	
	up/down	left/right	up/down	left/right
Mode 1	elevator	rudder	collective & throttle	aileron
Mode 2	collective & throttle	rudder	elevator	aileron

See also http://www.gpssoftware.com/glossary_m.htm.

RC Helicopter Primer

Helicopter Overview

Basic Structure of a Helicopter, Part 1
Basic Model Helicopter Control
Basic Principles of Helicopter Operation
Basic Structure of a Helicopter, Part 2
Overview of RC Helicopter Components

Helicopter Overview

Basic Principles of Operation



Model Helicopter Insights™
RC Helicopter Primer

- The physics of helicopter flight...
 - are very interesting.
 - can get complicated.
- A detailed understanding of all of the physics is not required...
 - for the basic ideas to make sense.
 - to get started and successfully fly RC helicopters.
- The following slides...
 - give an overview of helicopter operation.
 - provide a simplified perspective.
- For more details on helicopter flight physics refer to books, such as *Principles of Helicopter Flight* by W.J. Wagtendonk.

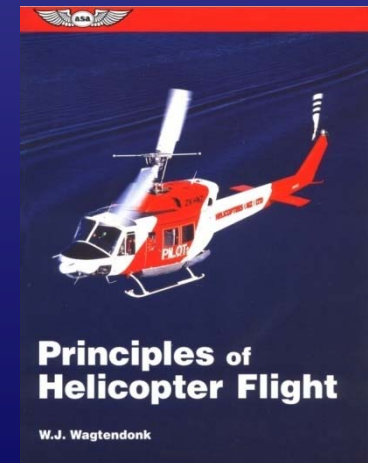

Helicopter Overview

Operation: Rotor Disc

Lift from the Main Rotor:

The rotor head, fly bar and main rotor blades make up the main rotor.



When the main rotor spins, the rotor disc can generate lift to raise the helicopter off the ground, into the air.



Above and to the right: Impala helicopter model from RealFlight G3 simulator
Also on the right: Futaba 7C radio control transmitter

Helicopter Overview

Operation: Rotor Blade

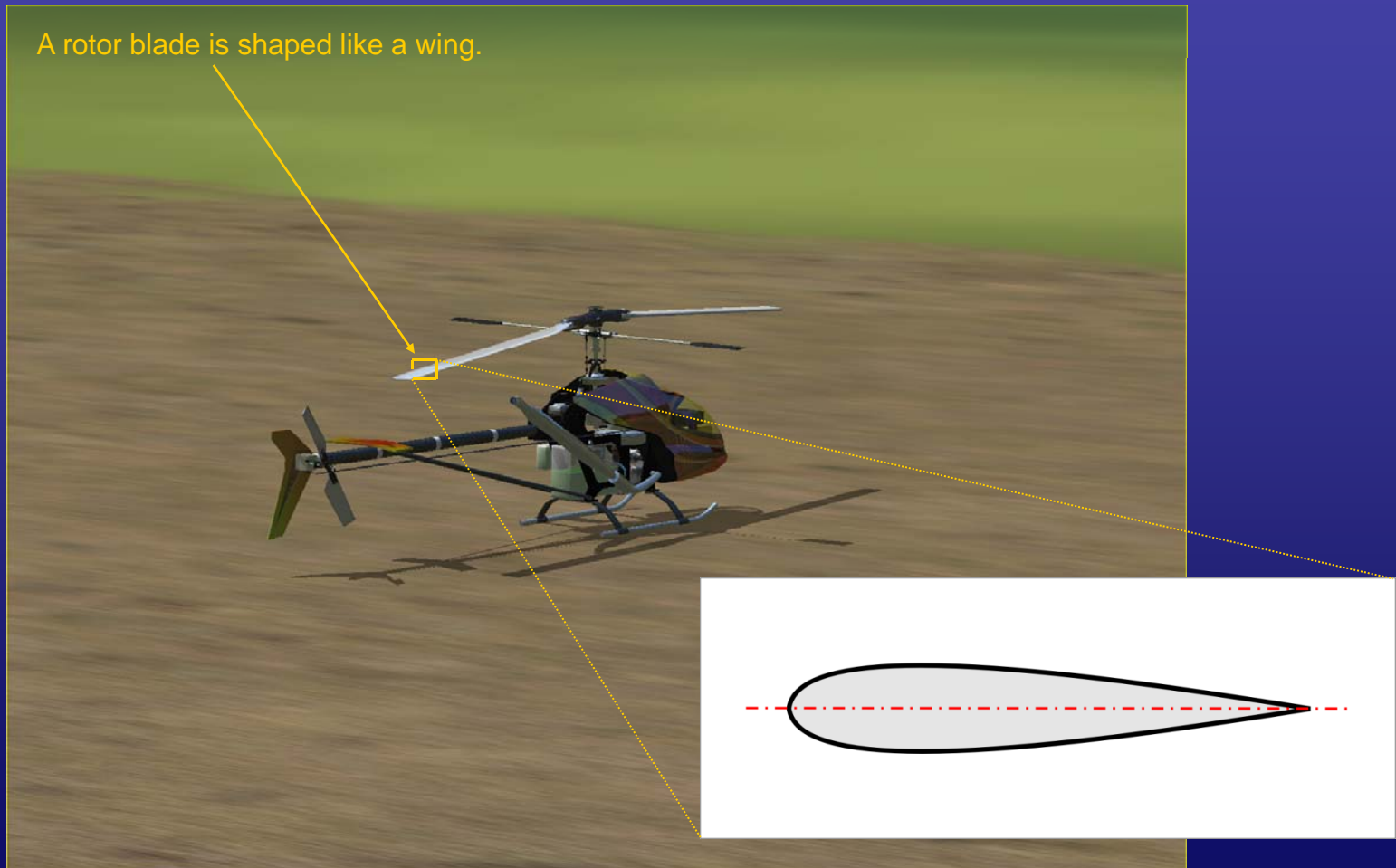

Above: Impala helicopter model from RealFlight G3 simulator

Helicopter Overview

Operation: Airfoils and Lift

- Helicopters are rotary wing aircraft: the main rotor consists of two (or sometimes more) wing-shaped blades that spin around the rotor shaft.
- When air flows over a wing or *airfoil*, lift is generated.
- The amount of lift increases when...
 - the airfoil's *angle of attack* increases.
 - the speed of the airflow increases.
- The angle of attack is the angle between the airflow and the center line or *chord line* of the airfoil.

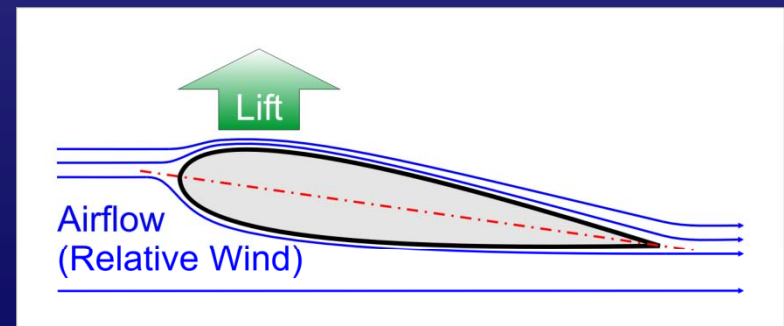
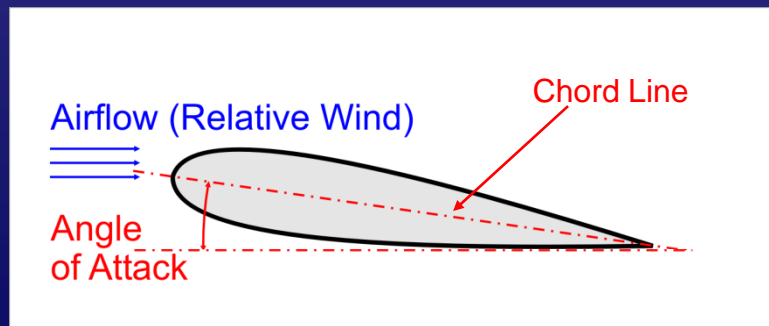

Helicopter Overview: Operation: Airflow



Model Helicopter Insights™
RC Helicopter Primer

- Airflow can come about in one of two ways (or a combination of the two).
 - The airfoil is stationary and air blows over the airfoil.
 - The air is still but the airfoil moves through the air.
 - Either way, there's a wind relative to the airfoil, and lift is generated.
- To keep things simple for this discussion, assume...
 - still air (i.e. no wind from the weather).
 - the airflow or *relative wind* over the blade is generated only by the rotation of the rotor.

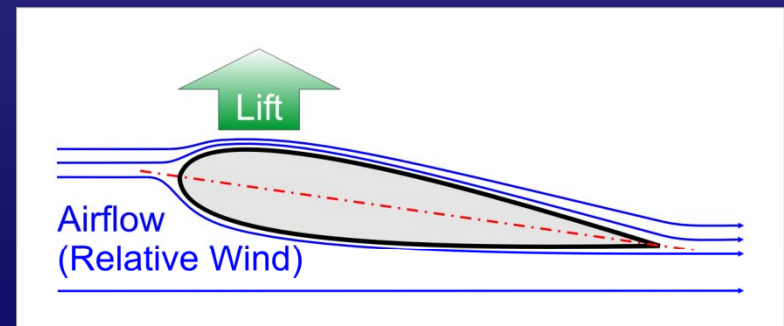

Helicopter Overview: Operation: Collective Pitch (1)

- Most helicopters vary the lift their main rotors generate by varying the angle of the rotor blades relative to the rotor disc.
- To control a helicopter's climb or descent, this angle or *pitch** of all main rotor blades is changed together.
- This control is the *collective pitch* control.

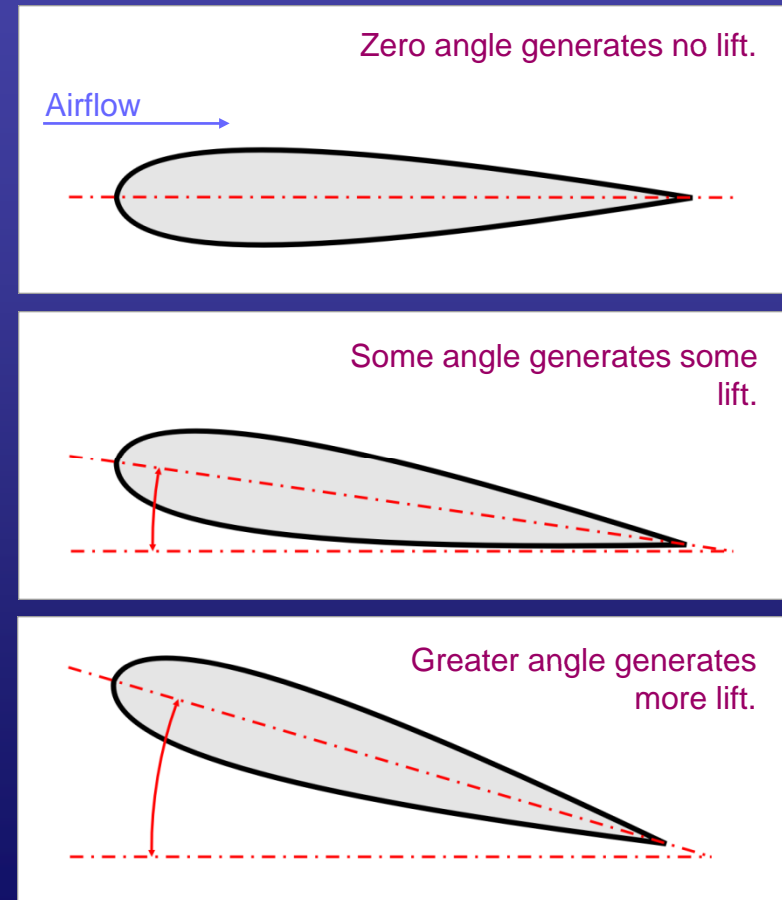

* Again note that in RC helicopter terminology the word “pitch” has different meanings in different contexts.

Helicopter Overview: Operation: Collective Pitch (2)

- The two pictures on this slide show rotor blades (white) attached to the rotor head (mostly black).
- The rotor head's mechanism allows the blades' pitch angles to be changed.
- As the leading edges of the rotor blades angle up, more lift can be generated.

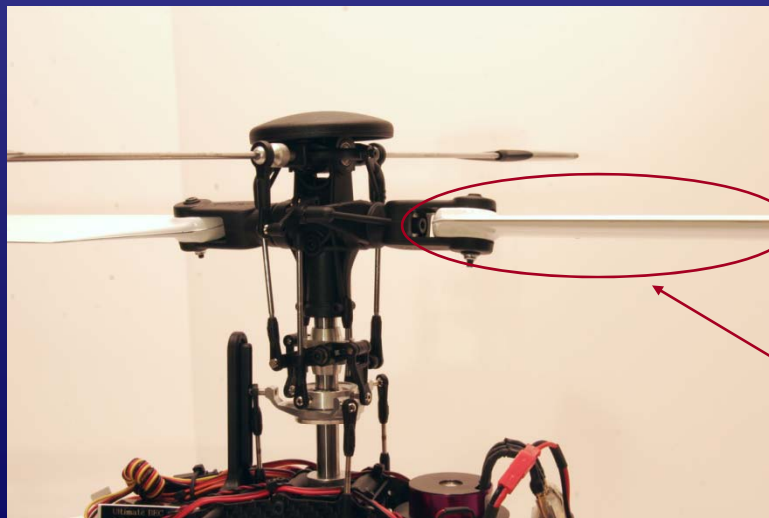
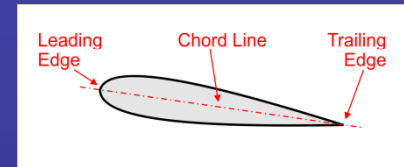

With increasing collective pitch, the leading edges of the rotor blades angle up for more lift.

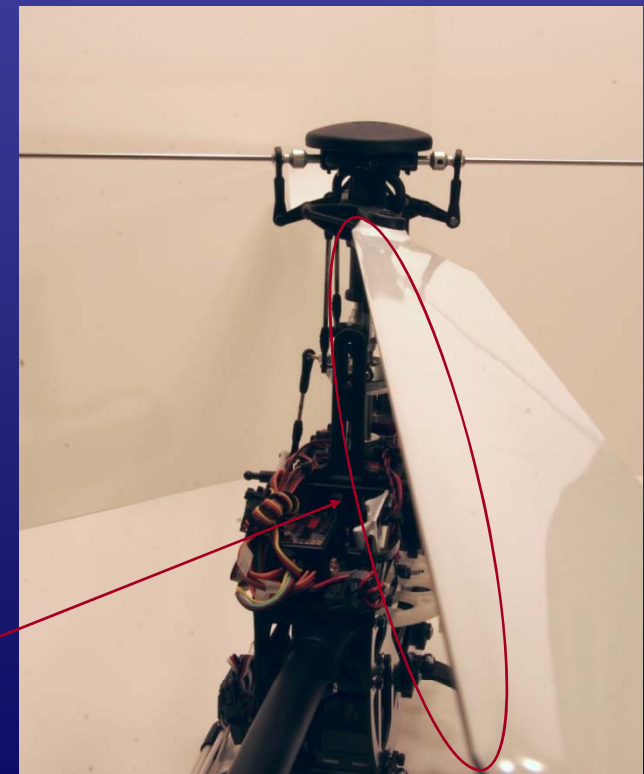

Left and above: Mikado Logo 10 Carbon rotor head
(Photos by W. Witt)

Helicopter Overview: Operation: Collective Pitch (3)

- The blades of a collective pitch model helicopter can be set up for negative pitch angles as well as positive ones.
- Negative pitch is required for inverted hovering and inverted flight.



Left: Mikado
Logo 10
helicopter

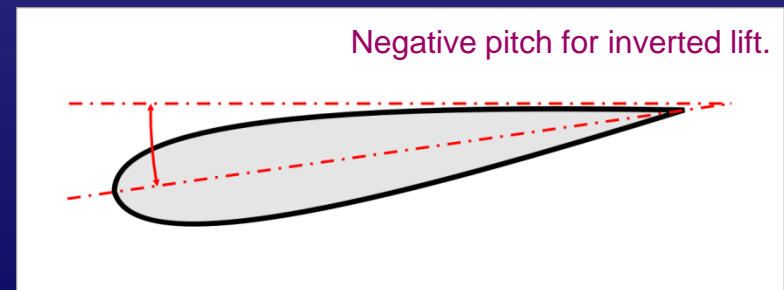
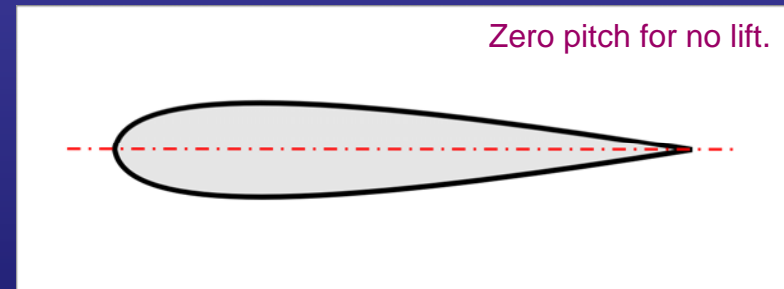
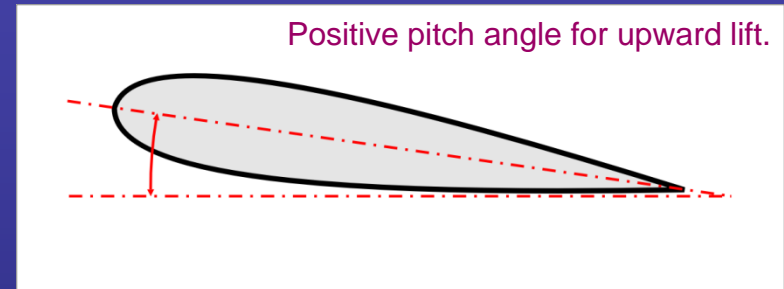

Helicopter Overview:

Operation: Pitch Angle Side Notes

- Two things to note:
 - The pitch angle is not necessarily the same as the angle of attack.
 - Pitch angle: angle between rotor blade chord and rotor disc.
 - Angle of attack: angle between rotor blade chord and airflow.
 - The airflow or relative wind is not always in the plane of the rotor disc.
 - For collective pitch helicopters, the rotor speed (i.e. rotations per minute) should stay constant as the blade angle or pitch changes.
- These two points...
 - are not critical at this time.
 - worth stating to keep the story straight.
 - will be useful later.

Helicopter Overview

Operation: Cyclic Pitch (1)



Model Helicopter Insights™
RC Helicopter Primer

- With collective pitch, the angles of all blades change together.
- Through the *cyclic pitch* control, the angle of a blade may be changed only when the blade travels through a certain part of the rotor disc (i.e. at a certain point in the rotor's cycle).
- Cyclic pitch example (right cyclic):
 - A rotor blade's angle increases and reaches its maximum when it passes over the helicopter's tail boom, and...
 - The blade's angle then decreases and reaches its minimum when it passes over the nose of the helicopter.
- Through this mechanism, the lift of the rotor disc may be redistributed to make the helicopter move in different directions.

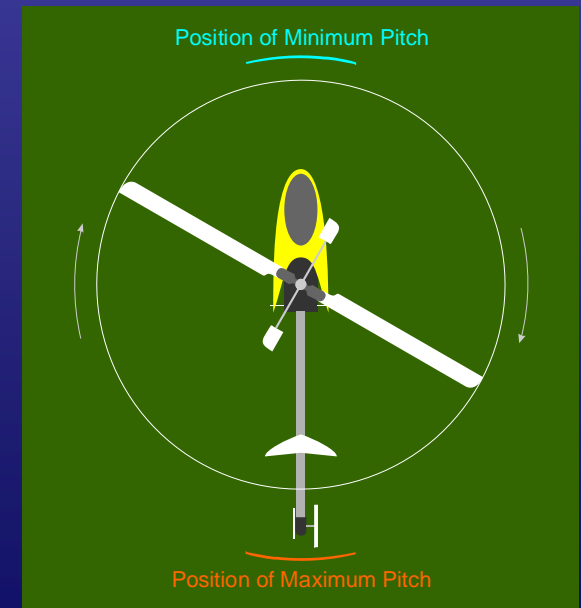

Helicopter Overview

Operation: Cyclic Pitch (2)

Lift Redistribution and Sideways Motion through the Cyclic Pitch Control:

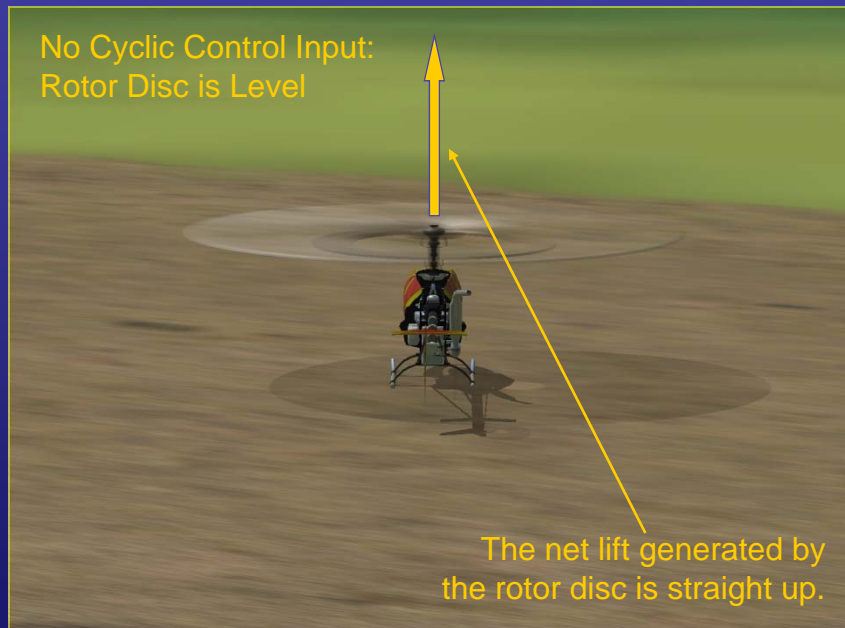

Above and to the right: Impala helicopter model from RealFlight G3 simulator
Top right: Futaba 7C radio control transmitter

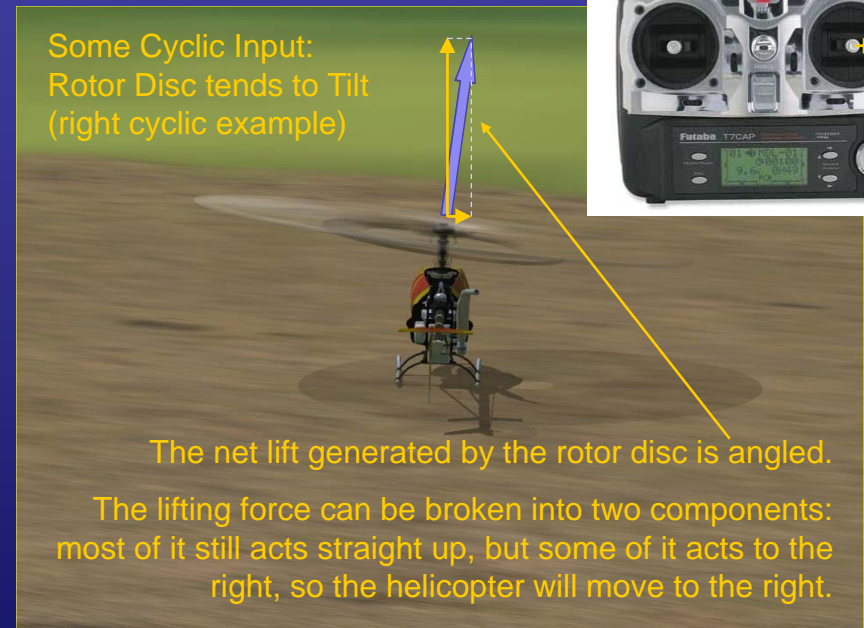

While this example shows the rotor disc tilting to the right with the helicopter subsequently moving (or rolling) to the right, the same concept applies to left, forward and backward motion.

Helicopter Overview

Operation: Tail Rotor

- Recall that a helicopter also has a tail rotor.
- The tail rotor is needed to control how the helicopter turns.
- Depending on tail rotor action, the helicopter's nose will...
 - swing to the right (clockwise).
 - swing to the left (counterclockwise).
- The tail rotor is working even (or especially) when the helicopter is not supposed to turn.



Above: Impala helicopter model from RealFlight G3 simulator

Helicopter Overview

Operation: Tail Rotor, Anti Torque



Model Helicopter Insights™
RC Helicopter Primer

Main Rotor Torque and Tail Rotor Action:

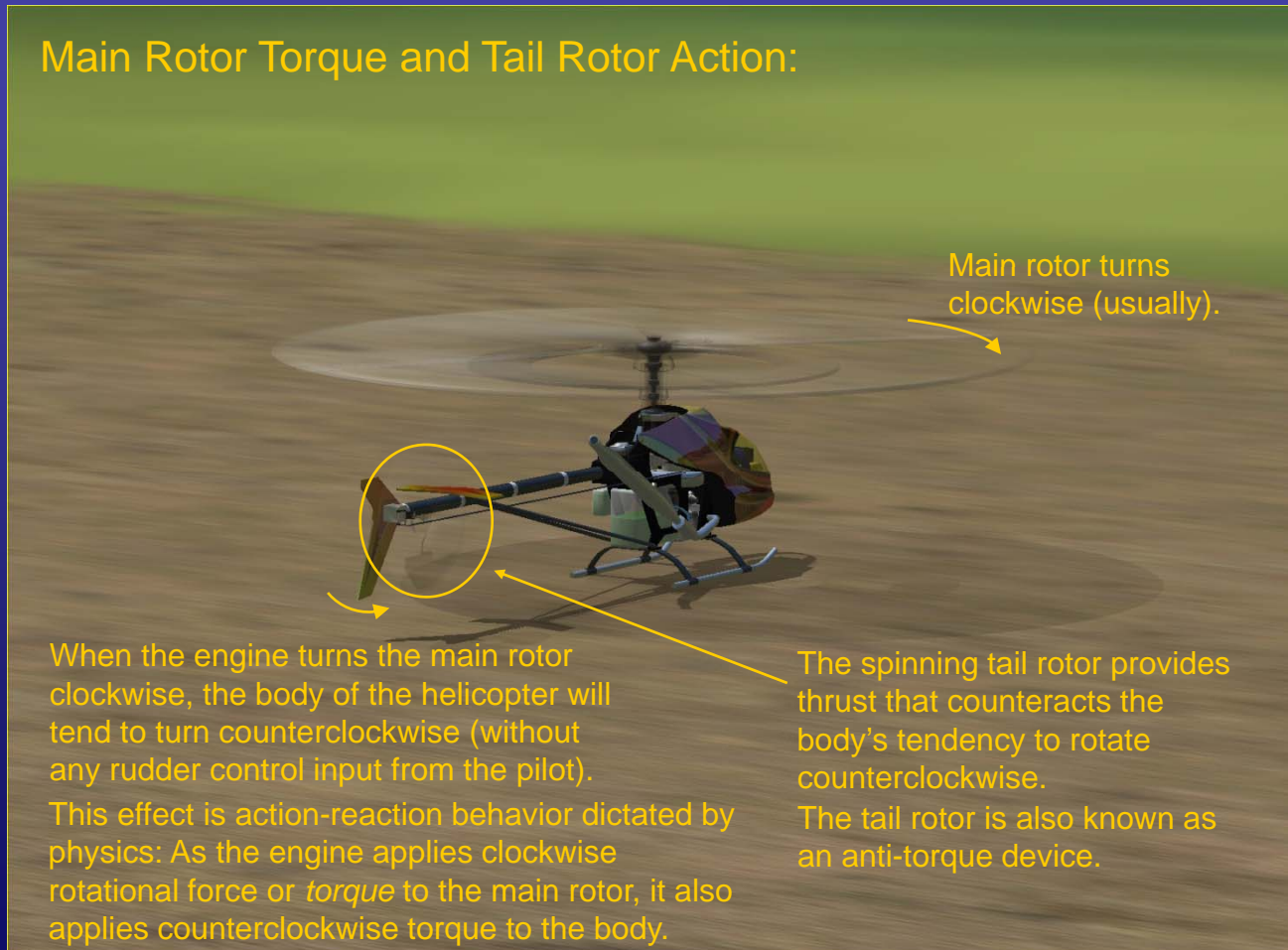

Above: Impala helicopter model from RealFlight G3 simulator

Helicopter Overview

Operation: Tail Rotor Pitch

- The pictures show the tail rotors of two RC helicopters.
- The pitch angle of the tail rotor blades is adjustable similar to the collective pitch of the main rotor.
- As the blade angle changes, the tail rotor can generate varying levels of thrust in either direction to control whether and how fast the helicopter turns.



Above: Century Falcon tail rotor

The pitch of the tail rotor is adjustable, providing a method to alter the tail rotor's thrust and thereby control how the helicopter turns.

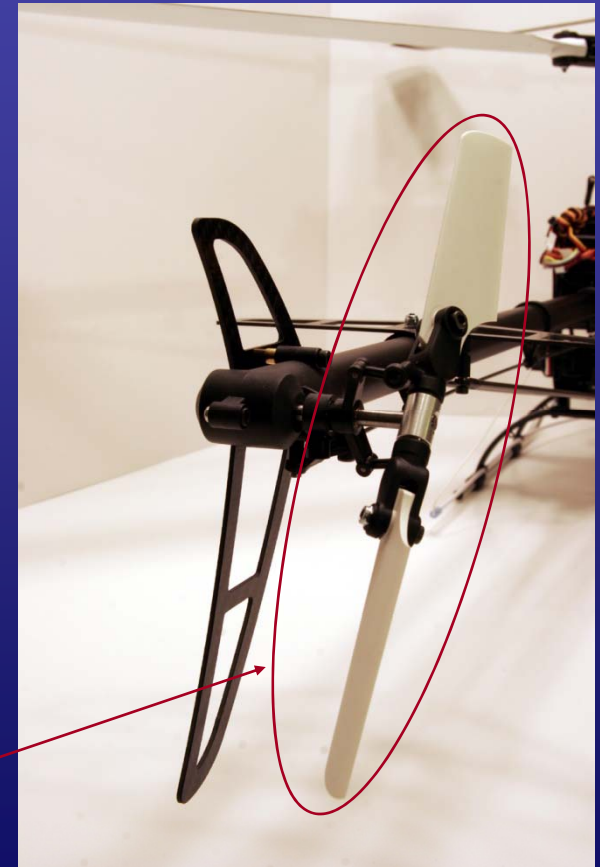

Above: Mikado Logo 10 Carbon tail rotor
(Photo by W. Witt)



RC Helicopter Primer

Helicopter Overview

Basic Structure of a Helicopter, Part 1
Basic Model Helicopter Control
Basic Principles of Helicopter Operation
Basic Structure of a Helicopter, Part 2
Overview of RC Helicopter Components

Helicopter Overview:

Basic Structure of a Helicopter – Part 2

- Frame
 - Engine or motor mount
 - Fuel tank or battery tray
 - Drive gears
 - Part of the rotor control mechanics and linkages
 - Mounts for the avionics
- Main rotor head and rotor
 - Swash plate
 - Pitch compensator / washout unit
 - Fly bar and paddles
 - Control linkages
 - Rotor blade grips and blades
- Tail
 - Tail boom with boom supports
 - Tail rotor
 - Vertical and horizontal fins
- Landing gear, skids
- Canopy



All four sample pictures show a Century Falcon 50-size helicopter.

Helicopter Overview

Structure, Part 2: Focus Areas



Model Helicopter Insights™
RC Helicopter Primer

- The next few slides provide a little more detail about the makeup of the more complicated pieces of the helicopter:
 - Frame (and the components it houses)
 - Rotor head
- Of the tail components...
 - the tail boom connects the tail to the main frame, while the boom supports provide additional points of support for the tail.
 - the tail rotor was covered a few slides ago.
 - the vertical and horizontal fins help stabilize the helicopter during forward flight, although...
 - some aerobatic helicopter models forgo the horizontal fin.
 - the vertical fin also serves to keep the tail rotor from hitting the ground.
- Beyond that...
 - the skids are something for the helicopter to land and stand on.
 - the canopy is the shell around the helicopter's frame at the front.

Helicopter Overview

Structure 2: Frame Components (1)

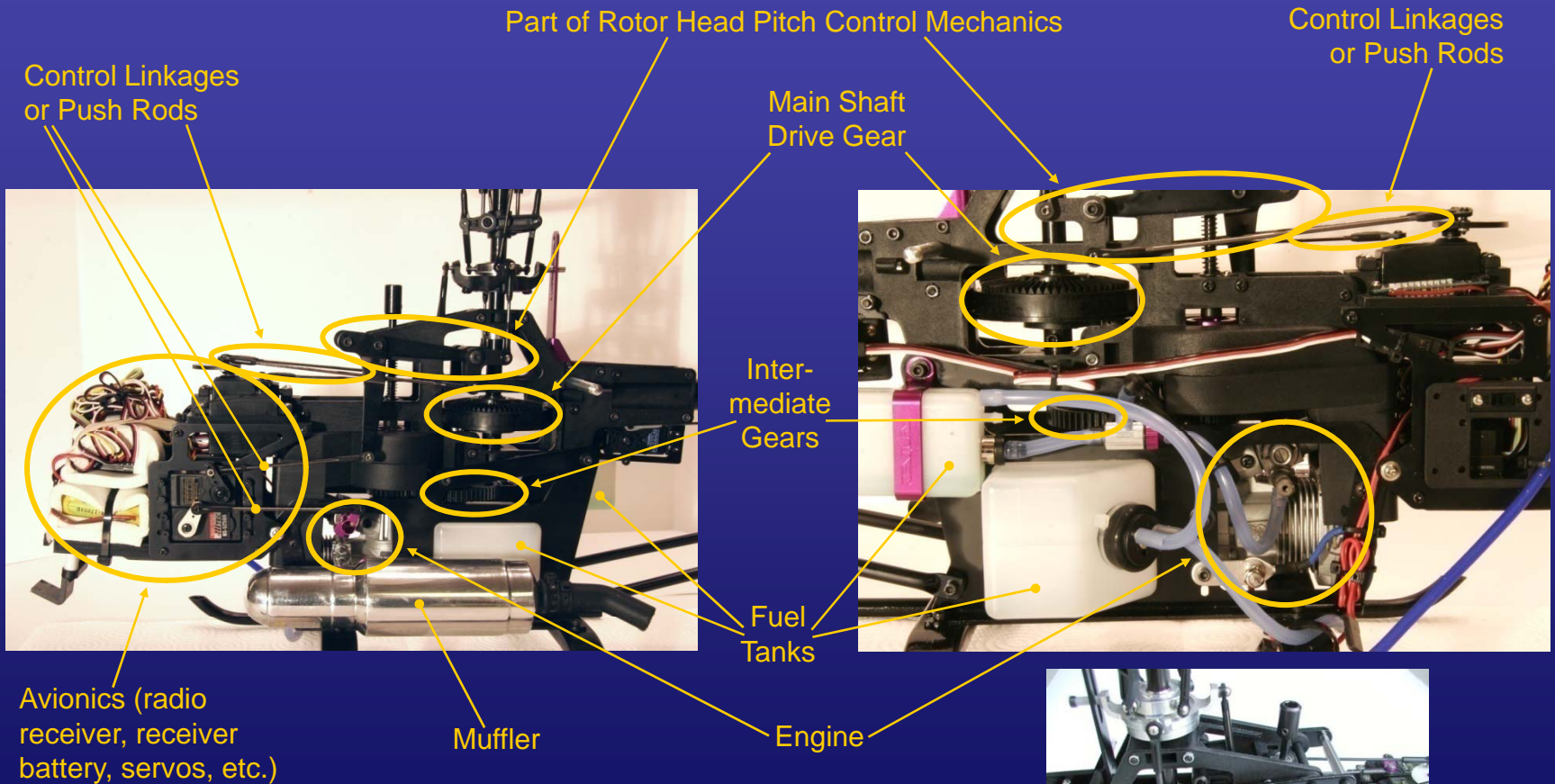

The helicopter in these pictures is a Century Hawk/Falcon. While other helicopters will look different, similar components will be present.

Above: Century Hawk Pro
(Photos by W. Witt)

Right: Century Falcon
(the two have similar frames)



Helicopter Overview

Structure 2: Frame Components (2)



This example shows a Century Predator 60 helicopter.

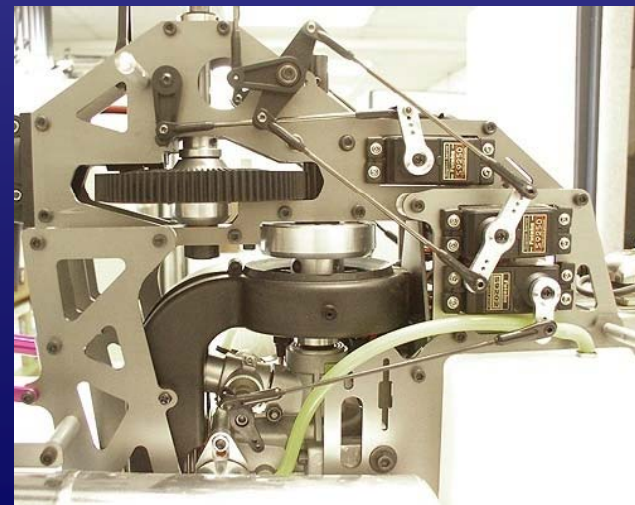
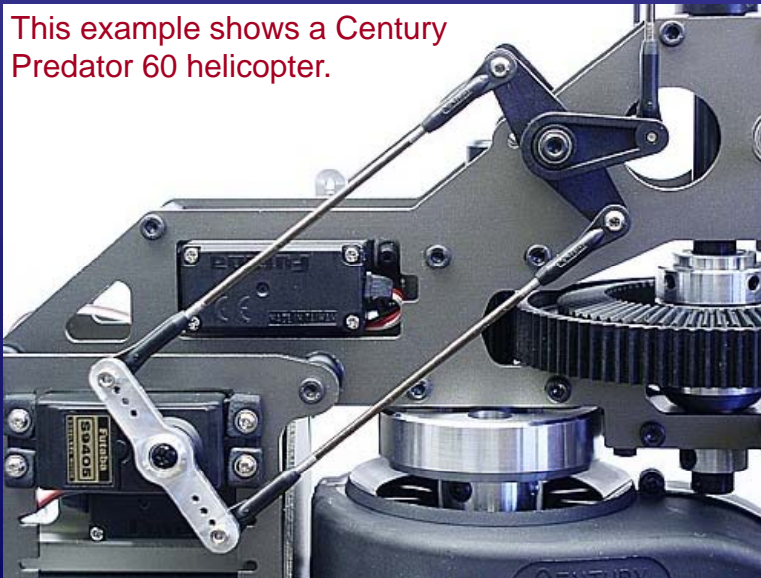
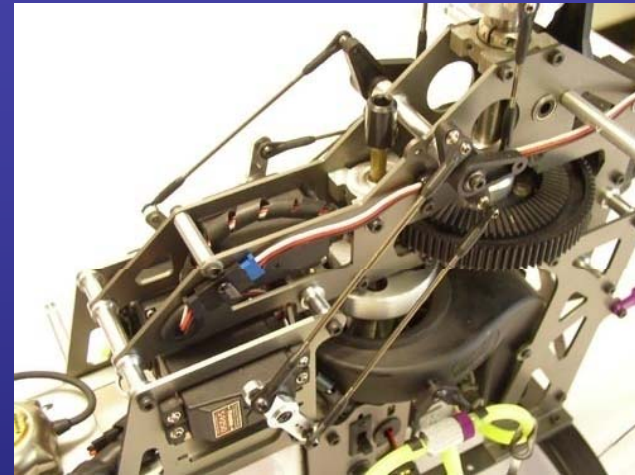

Century Predator 60 Helicopter

Helicopter Overview

Structure 2: Rotor Head Components

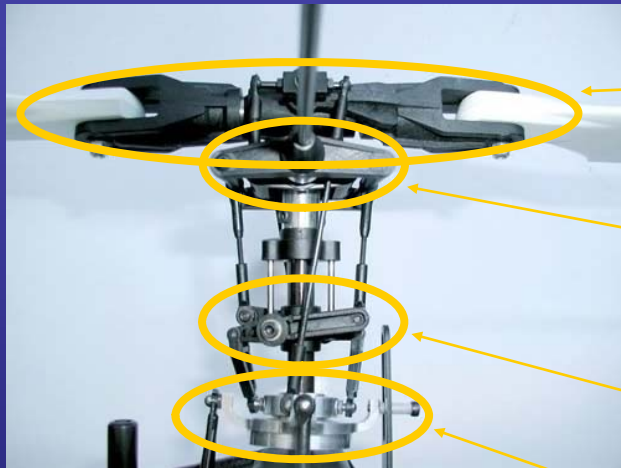

Century Falcon 50 rotor head

Main Rotor Blade Grips
with Blades

Fly Bar Seesaw
with Fly Bar
and Paddles

Washout Unit
or Pitch Compensator

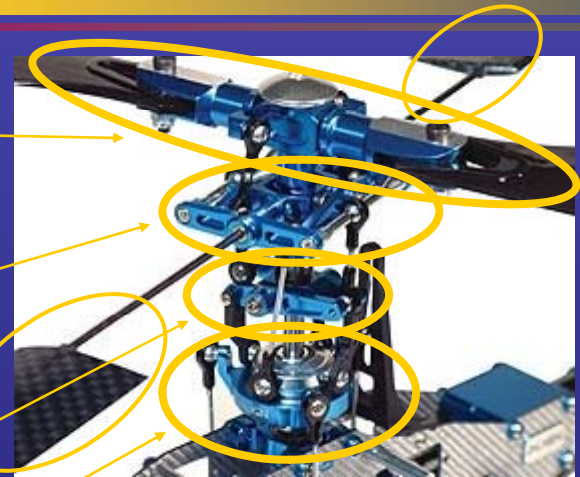

Align T-Rex 450 SE rotor head

Swash Plate



Century metal swash plate



Align metal eCCPM swash plate

Helicopter Overview

Structure 2: Swash Plate

- The *swash plate* is a very prominent and important part of the rotor head mechanism.
- The swash plate...
 - is the interface between the non-rotating and rotating pieces of the rotor head.
 - transfers collective and cyclic pitch change commands from the non-rotating body of the helicopter to the rotating rotor head.
 - Raising or lowering the swash plate translates into increases or decreases in collective pitch. *
 - Angling the swash plate in one direction translates into cyclic pitch changes.



Above: Align T-Rex 450 SE rotor head



Above: Align metal swash plate

* On most rotor heads, raising the swash plate maps to an increase in collective pitch. A few rotor heads, however, work the other way around, such that *lowering* the swash plate increases collective pitch and vice versa.

Helicopter Overview

Structure 2: Swash Plate, Collective



Model Helicopter Insights™
RC Helicopter Primer

As the swash plate rises, control linkages (or push rods) and arms on hinges translate that motion into an increase in collective pitch.



Above: Mikado Logo 10 Carbon rotor head (Photo by W. Witt)



Above: Mikado Logo 10 Carbon rotor head (Photo by W. Witt)

Helicopter Overview

Structure 2: Swash Plate, Cyclic



Model Helicopter Insights™
RC Helicopter Primer

Angling the swash plate causes cyclic pitch changes.

With cyclic pitch, the blade angle will continually change as the rotor disc spins, reaching a maximum angle at one point in the rotation and a minimum angle at the opposite point (i.e. half a turn or 180° away).

The direction the swash plate is angled determines where in the rotor's rotation the blade angle maximum and minimum occur and which way the helicopter will move as a result.

The swash plate mechanism mechanically mixes or overlays the collective and cyclic pitch controls.

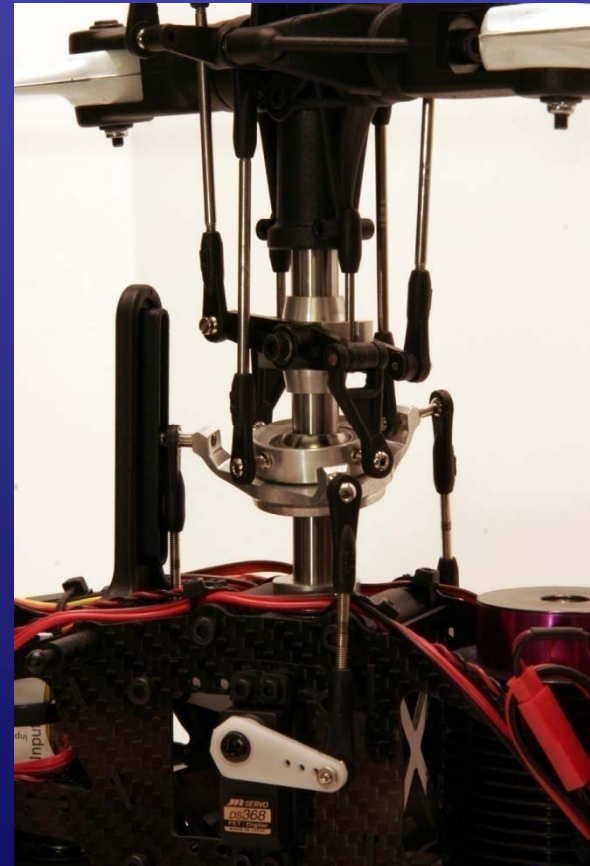

Above: Mikado Logo 10 Carbon rotor head
(Photo by W. Witt)

Helicopter Overview

Structure 2: Swash Plate, Rotation



Model Helicopter Insights™
RC Helicopter Primer

- During flight, the top of the swash plate rotates while the bottom does not.
- Two examples:
 - No cyclic input (left photo)
 - Forward cyclic (right photo)

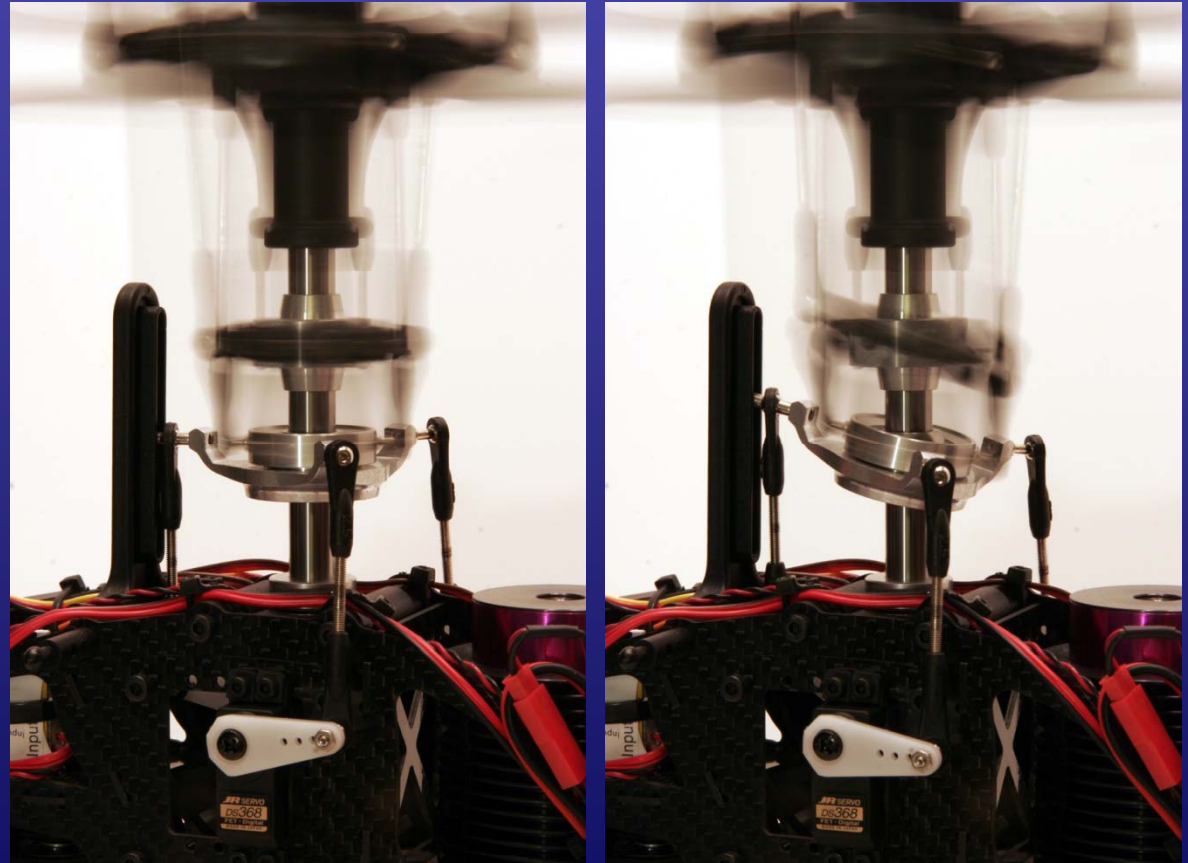

Above: Mikado Logo 10 Carbon rotor head (Photos by W. Witt)

Helicopter Overview

Structure 2: Fly Bar (1)

- The *fly bar*...
 - consists of a rod with airfoil-shaped paddles on its ends.
 - is mounted to the rotor head through a seesaw that allows it to pivot.
 - responds only to cyclic control inputs.
 - With no cyclic control input, the paddle's blade angle is zero degrees relative to the rotor disc, regardless of the amount of collective pitch on the main rotor blades.
 - With cyclic input, the paddles change angle during the rotor's rotation in the same fashion as the main rotor blades.
- During flight...
 - the fly bar stabilizes the helicopter.
 - cyclic control inputs...
 - first have a relatively small effect on the main blades but a large effect on the fly bar paddles.
 - second cause the disc of the rotating fly bar to tilt.
 - third, as a result of the fly bar disc's tilt, increase the cyclic pitch of the main blades.
- Models (especially smaller ones) without fly bars tend to be difficult to hover and fly.

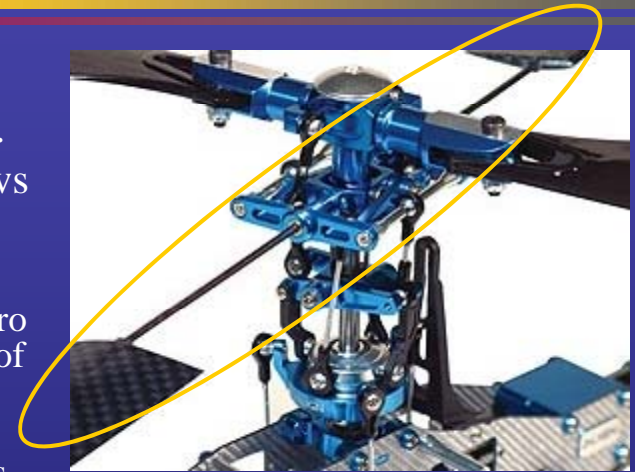

Top to bottom: Align T-Rex 450 SE rotor head, Mikado Logo 10, Thunder Tiger Raptor 30

Helicopter Overview

Structure 2: Fly Bar (2)

- Cyclic control inputs are...
 - not immediately fully transferred to the main blades.
 - affect the main blades mostly through the fly bar.
- The characteristics of the fly bar...
 - have a large impact on how responsive the helicopter is.
 - may be tuned to adjust the helicopter's control sensitivity.
- Cyclic control sensitivity and helicopter roll rate increase as...
 - the fly bar becomes longer.
 - the paddles become lighter.
 - the airfoil shape of the paddles becomes more aggressive.

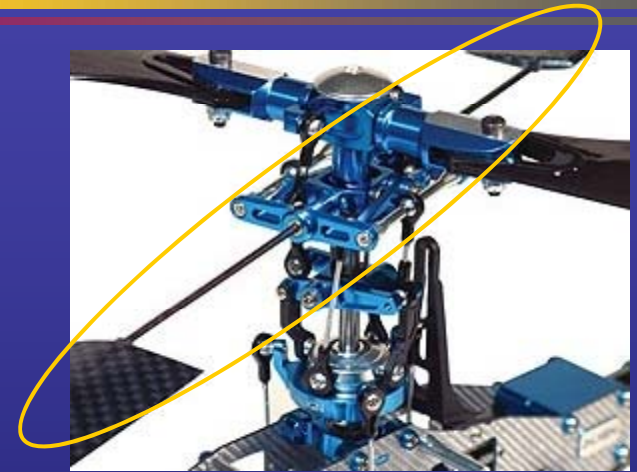

Top to bottom: Align T-Rex 450 SE rotor head,
Mikado Logo 10, Thunder Tiger Raptor 30

Helicopter Overview

Structure 2: Fly Bar (3)

- Full-size helicopters...
 - may also have fly bars.
 - may have stabilizer bars with weights instead of paddles.
 - often don't need fly bars because they are inherently sufficiently stable.
- Electronic stabilizers (a.k.a. virtual fly bars) using gyro-like technology...
 - have become available for RC models.
 - eliminate the need for mechanical fly bars and paddles.
 - tend to make the rotor more power efficient (due to reduced drag).
 - slightly change a helicopter's flight characteristics.*
 - can be expensive and tricky to set up.



Top to bottom: Mikado Logo 600 helicopter without mechanical fly bar, Mikado fly bar-less rotor head, Mikado V-Stabi virtual fly bar electronics unit



* The flight characteristics are not necessarily better but different.

Helicopter Overview

Structure 2: Pitch Compensator

- The *washout unit* or *pitch compensator*...
 - connects the swash plate to the fly bar seesaw.
 - keeps collective pitch changes from affecting the fly bar, that is the paddle angle stays at zero degrees even while the swash plate rises or falls.
 - only allows the cyclic pitch control to change the angle of the paddles.
- Helicopters without mechanical fly bars do not need this component.



Above: Align T-Rex 450 SE rotor head



RC Helicopter Primer

Helicopter Overview

Basic Structure of a Helicopter, Part 1
Basic Model Helicopter Control
Basic Principles of Helicopter Operation
Basic Structure of a Helicopter, Part 2
Overview of RC Helicopter Components

Helicopter Overview

Overview of Components



Model Helicopter Insights™
RC Helicopter Primer

- Helicopter kit
- Power system
 - Internal combustion (IC) power
 - Engine
 - Glow fuel
 - Gasoline
 - Muffler or tuned pipe
 - Fuel
 - Electric power (EP)
 - Electric motor
 - Electronic speed controller
 - Motor battery
- Avionics
 - Servos
 - Gyro
 - Radio receiver
 - Radio transmitter
- Additional items
 - Tools to assemble everything
 - Battery charger
 - Field equipment
 - Extended landing gear for initial practice
 - RC flight simulator

Helicopter Overview

Components: Helicopter Kit

- Frame
 - Engine or motor mount
 - Fuel tank or battery tray
 - Drive gears
 - Parts of the rotor control mechanics
 - Mounts for the avionics
- Main rotor head and rotor
 - Swash plate
 - Pitch compensator or washout hub
 - Control linkages
 - Fly bar and paddles
 - Rotor blade grips and blades
- Tail
 - Tail boom with boom supports
 - Tail rotor
 - Vertical and horizontal fins
- Landing gear, skids
- Canopy



All four sample pictures here show a Century Falcon 50-size helicopter.

Helicopter Overview

Components: Power System

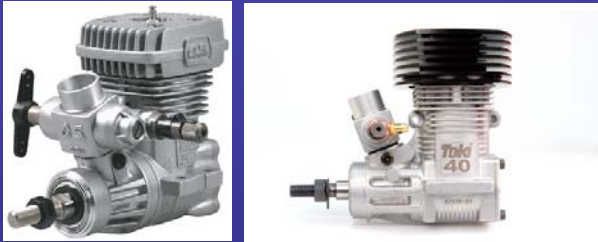

Above: 30-size glow engines: OS 37 (left), Toki 40 (right)



Above: exhaust systems: Century muffer (left), Curtis Youngblood's Muscle Pipe 30 (right)



Above: model engine glow fuel: assorted types of Morgan Fuel (left) and Byron Fuel (right)



Above: electric motors (brushless): Plettenberg Orbit (top left), Align 400LF (top middle), NEU (top right), Hacker C50XL-series (bottom left), Astro 020 803T (bottom right)



Above: electronic speed controllers (ESCs) for brushless motors: Schulze Future (top), Kontronik Jazz (middle), Hyperion (bottom)



Left and below: motor batteries: Apogee lithium polymer (LiPo) batteries (left), Thunder Power LiPo battery (middle), Nickel Metal-Hydrate (NiMH) battery pack (right)



The items shown on this slide are meant as examples only; the intent is not to recommend or endorse any particular product.

Helicopter Overview

Components: Avionics



Above: servos: Futaba S9001 (left), HiTec HS-525BB (middle), JR DS 368 (right)



Above: gyros: E-flite EFLRG90L (left), Futaba GY401 (middle), LogicTech LTG-2100T (right)



Left: receivers: Futaba R149DP 9-channel 72MHz PCM receiver (top left), JR R2000 scanning, synthesized, 10-channel 72MHz PCM receiver (top middle), Spektrum AR7000 7-channel 2.4GHz receiver (top right), HiTec Neutron 6S 6-channel 72MHz PPM receiver (bottom left), Berg7 7-channel 72MHz PPM receiver (bottom middle), typical 4-cell NiCd receiver battery (bottom right)



Above and to the right: radio transmitters: Futaba 9CH 72MHz transmitter (top left), JR XP9303 72MHz transmitter (top right), Spektrum DX7 DSM2 2.4GHz spread spectrum transmitter (bottom right)



The items shown on this slide are meant as examples only; the intent is not to recommend or endorse any particular product.

Helicopter Overview: Components: Tools, Accessories



Above: Century field equipment starter pack for glow helicopters including engine starter, starter battery with charger, manual fuel pump, glow plug heater with charger
Left: Century basic tool starter set



Above: multi-purpose, fast battery chargers: ElectriFly Triton (top left), Schulze isl 6-330d (top right), Orbit Microlader (bottom left), Accu-Cycle Elite (bottom left)

The items shown on this slide are meant as examples only; the intent is not to recommend or endorse any particular product.

Below: Extended helicopter landing gear for training flights

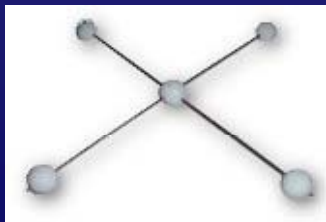

Below: RC flight simulators: Phoenix RC (left), Reflex XTR (middle left), RealFlight G3.5 (middle right), ClearView (right)

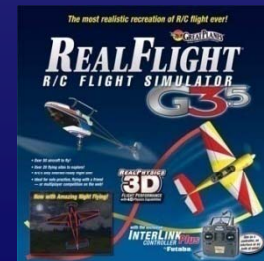

RC Helicopter Primer

End of Helicopter Overview

Basic Structure of a Helicopter, Part 1
Basic Model Helicopter Control
Basic Principles of Helicopter Operation
Basic Structure of a Helicopter, Part 2
Overview of RC Helicopter Components



RC Helicopter Primer

RC Helicopter Component Details

Power Systems

Servos

Helicopter Kits

Gyros

Governors

Automatic Mixture Controllers

Transmitters and Receivers

BECs / Voltage Regulators

Multi-Function Modules

Tools and Equipment

RC Helicopter Components

Introduction

- The following slides provide additional information about...
 - the types of helicopter kits that are available.
 - the components that are required to equip and build such a helicopter.
- The slides begin with power systems and servos.
- The discussion about helicopter kit types will make more sense with some understanding of power systems and servos.
- The presentation then continues with gyros, governors, transmitters, receivers as well as additional equipment and tools.



RC Helicopter Primer

RC Helicopter Component Details

Power Systems

Servos

Helicopter Kits

Gyros

Governors

Automatic Mixture Controllers

Transmitters and Receivers

BECs / Voltage Regulators

Multi-Function Modules

Tools and Equipment

RC Helicopter Components

Power Systems

- RC model helicopters are propelled through one of two types of power:
 - Internal combustion (IC) power
 - Electric power (EP)
- Neither of these types is inherently better than the other.
- Each type has some advantages and disadvantages.

RC Helicopter Components

Internal Combustion Power

- Internal combustion (IC) engines for model aircraft are most commonly two-stroke *glow fuel* engines.
- Glow fuel engines...
 - run on a methanol-based fuel. (Methanol is a type of alcohol.)
 - use glow plugs, which serve a function similar to spark plugs.
 - To start the engine, the glow plug is heated using energy from a battery.
 - The heat from the glow plug ignites the fuel mixture in the engine.
 - Once the engine has started, the heat from the combustion process keeps the plug hot, so the engine keeps running.
- Glow engines are relatively simple, yet effective power plants.
- On one tank of fuel, a glow fuel helicopter flies for 5 to 20 minutes (with approximately 7 or 8 minutes as a typical average).*

* The flight time from one tank depends on multiple factors; your flight time will vary.



Above: OS8 glow plug (top), OS 32 glow engine (bottom)

RC Helicopter Components

IC Power: Glow Engines (1)

- Glow engines are available in different sizes and power levels.
- An engine's size is specified by the *displacement volume* of its combustion chamber.
- For example, a 32-size engine has a displacement of 0.32 cubic inches (*cu in* or *in³*).
- Helicopter engines range in size...
 - from about 0.30 cu in.
 - to about 0.90 cu in.



Above: OS 32 SX-HX (left), OS 37 SZ-H Ring (middle), Toki 40 (right)

RC Helicopter Components

IC Power: Glow Engines (2)

- Power output increases with increasing displacement.
 - 30-size: approx. 1 horsepower
 - 90-size: approx. 3 horsepower
- Larger engines (especially 90-size) also...
 - consume fuel more quickly than smaller ones.
 - tend to have more complicated carburetors, possibly making the tuning process more complex.
- Engines for entry-level helicopters are typically in the neighborhood of 0.30 to 0.50 cu in.



Above: OS 50 SX-H Ring Hyper (left), YS 50ST (middle), Thunder Tiger Redline 53 (right)

RC Helicopter Components

IC Power: Mufflers and Pipes (1)



Model Helicopter Insights™
RC Helicopter Primer

- A glow fuel engine requires a *muffler* to...
 - reduce the noise the engine makes.
 - provide back pressure* through the engine's exhaust port to facilitate the engine's proper operation.
- A *tuned pipe*...
 - is a special type of muffler.
 - compares to a basic muffler in that it...
 - is more expensive.
 - is tuned to the engine's operating behavior with the objective of maximizing the engine's power output by optimizing the exhaust back-pressure characteristics.
 - is intended for a particular engine speed (i.e. RPM).
 - usually requires a relatively complicated process to tune the engine/pipe combination.



Above (top to bottom): 30-size Century Speed Torpedo muffler, Hatori tuned pipe for OS32

* Understanding why back pressure is important requires knowledge of two-stroke engine design and operation. Those details are beyond the scope of this presentation.

RC Helicopter Components

IC Power: Mufflers and Pipes (2)



Model Helicopter Insights™
RC Helicopter Primer

- A *tuned muffler*...
 - is a hybrid of a basic muffler and a tuned pipe.
 - has a more complicated internal arrangement than a basic muffler.
 - is easier to tune than a pipe.
 - makes better power than a basic muffler.
 - should perform well across a broader range of engine speeds relative to a pipe.
- A simple muffler...
 - may be included in an entry-level IC power helicopter kit.
 - is generally sufficient for an entry-level helicopter.
- Tuned pipes are rarely used; most high-performance glow helicopters are equipped with tuned mufflers.



Above (top to bottom): 30-size Century Speed Torpedo muffler, Hatori tuned pipe for OS32, Hatori tuned muffler for OS37, Curtis Youngblood's Muscle Pipe 30 (a tuned muffler)

RC Helicopter Components

IC Power: Glow Fuel (1)



Model Helicopter Insights™
RC Helicopter Primer

- Glow fuel is a mixture of...
 - combustible liquids.
 - methanol, a type of alcohol
 - nitromethane, a power-boosting agent
 - lubricants.
 - castor oil
 - synthetic oil
- In the US, helicopter fuel usually contains...
 - 15, 20 or 30% nitromethane.
 - at least 17% lubricant.
- In other countries, the typical nitromethane content may be lower, and engine designs may be slightly different to compensate.*
- Helicopter fuel tends to be different from airplane fuel.
- Because helicopter engines operate under different conditions, helicopter fuel tends to require a stronger mix of lubricants.
- Because glow fuel contains nitromethane, glow fuel helicopters are sometimes referred to as *nitro-powered* helicopters.



Above (left to right): three types of glow fuel by Morgan Fuel, Byron Fuel, Wildcat Fuel, Magnum Fuel

* The difference is in compression ratio.

RC Helicopter Components

IC Power: Glow Fuel (2)

- 15% nitro glow fuel...
 - produces a bit less power.
 - is significantly less expensive, as ethanol is relatively cheap.
 - may cause the engine to be slightly more difficult to tune.
 - works in a leaner mixture,* resulting in a lower fuel consumption rate and slightly longer flight times.
 - produces less nitric acid as a result of imperfect combustion.
 - is generally sufficient for beginning and even intermediate pilots.
- 30% nitro glow fuel...
 - produces a bit more power.
 - is more expensive due to the higher nitromethane content.
 - may cause the engine to be slightly easier to tune.
 - requires the engine to be run a little richer,* so that fuel is consumed more quickly.
 - produces more nitric acid that may accelerate engine wear and attack paint exposed to engine exhaust.
 - is beneficial especially for aggressive aerobatic maneuvers.

* More about lean and rich mixtures shortly.

RC Helicopter Components

IC Power: Engine Tuning (1)

- Glow engines need to be tuned to operate properly and reliably.
- Tuning involves dialing in the fuel-to-air ratio or mixture.
 - There's an optimal mixture where the engine will...
 - produce its best power.
 - remain sufficiently lubricated.
 - not run too hot.
 - not stop running unexpectedly.
 - A mixture with a...
 - higher fuel-to-air ratio (i.e. more fuel) is a rich mixture.
 - lower fuel-to-air ratio (i.e. less fuel) is a lean mixture.
- New engines benefit from a wear-in or break-in period during which they should be run slightly richer than normal.
- Engines that are run too lean will eventually die an early death.



Low-End Mixture Control Screw

High-End Mixture Control Valve



Above: OS 37 SZ- H Ring engine

RC Helicopter Components

IC Power: Engine Tuning (2)

- Tuning an engine can be a difficult task to the uninitiated.
- Commonly dispensed engine tuning advice includes:
 - “Look at the smoke coming out of the exhaust. Make sure it’s enough.”
 - “Touch the engine after a flight, and make sure it’s not too hot.”
 - “Listen to the engine. If it sounds like it’s running rich, lean it; if it sounds lean, richen it.”
 - “Feel the response and power of the engine during flight, and tune it accordingly.”
- But these pieces of advice may not be all that helpful to a newcomer pilot.
 - *How much smoke is enough (especially since the amount of smoke also depends on engine size and the brand of fuel)?*
 - *How hot is too hot (especially since different people’s fingers will perceive heat a bit differently)?*
 - *What do “rich” and “lean” sound like exactly?*
 - *Hey, I can barely get this thing off the ground without crashing. What do I know about how the engine feels during flight???*

RC Helicopter Components

IC Power: Engine Tuning (3)

- For a given helicopter, the ideal engine setting depends on...
 - engine type.
 - fuel brand and type.
 - muffler type.
 - glow plug heat level.
 - ambient temperature.
 - other factors.
- Engines' user's manuals sometimes include tuning instructions, but they may be overwhelming to a new pilot.
- Of course, lots of people get their engines to run, so it can be done.*

* See the *Tips to Get Started: Helicopter Setup and Checkout* section for general tips in case you need but can't get help.

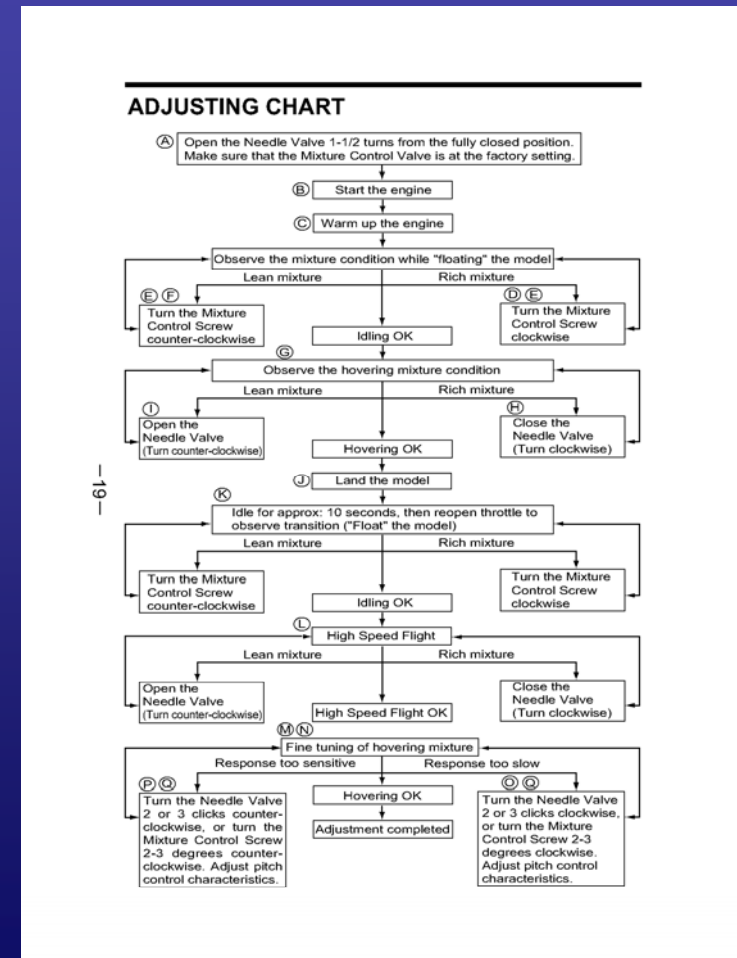

Above: Tuning flow chart from OS 32 SX- H engine user's guide.

RC Helicopter Components

IC Power: Glow Plugs (1)



Model Helicopter Insights™
RC Helicopter Primer

- Glow plugs for glow engines are available in different heat levels.
- The heat level affects engine...
 - ignition timing.
 - colder plug: later ignition
 - hotter plug: earlier ignition
 - tuning.
 - power.
- Using OS-brand glow plugs as examples...
 - A No.8 plug is a medium-heat (i.e. “medium”) plug.
 - A No.7 plug is a bit hotter (i.e. “medium hot”).
 - A No.6 plug is hot.



RC Helicopter Components

IC Power: Glow Plugs (2)

- Other manufacturers (e.g. Enya) make similar glow plugs.
- Glow plugs of different brands are usually interchangeable (e.g. an Enya 3 is similar to an OS 7).
- Most helicopter glow engines (30 size through 90 size) will run well with medium plugs (e.g. OS 8).
 - Small engines (e.g. 30-size) sometimes run better with hot plugs (e.g. OS 6).
 - Large engines (e.g. 90-size) usually do not need hot plugs and run best with medium plugs (e.g. OS 8).



RC Helicopter Components

IC Power: Header Tanks

- Many IC helicopters are outfitted with header tanks.
- A header tank...
 - is a small fuel tank that is placed between the main tank and the engine.
 - can make an engine run better by providing more consistent fuel flow as it...
 - ensures that the engine is always drawing fuel from a full tank, even as the main tank drains.
 - prevents air bubbles that form in the main tank from reaching the engine.
- Without a header tank, air bubbles are more likely to get into the fuel feed to the engine, thereby causing temporary lean mixture conditions.

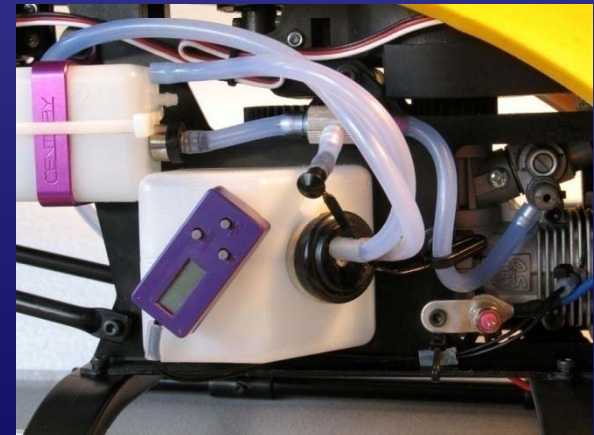
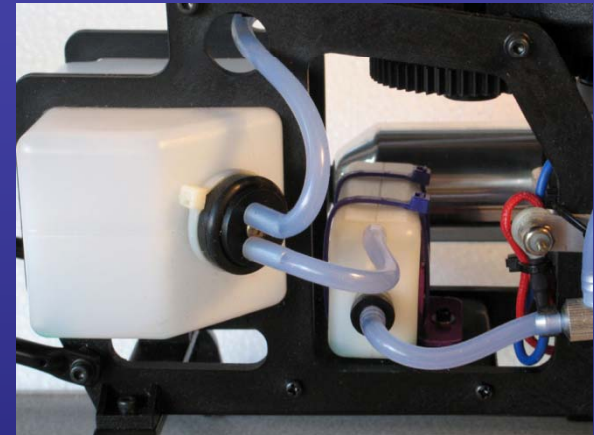

Above: Main tank and header tank installed in a Century Hawk Sport helicopter (top); main tank and header tank in a Hawk Pro (bottom). Stuck to the main tank of the Hawk Pro is an on-board temperature meter with its sensor attached to the engine (sensor not shown).

RC Helicopter Components

IC Power: Gasoline

- Some helicopters run off two-stroke gasoline engines.
 - Gasoline is cheaper than glow fuel.
 - Gasoline engines...
 - offer longer run times.
 - make sounds that are more similar to full-size helicopters.
 - are more complex and expensive than glow fuel engines.
- Gasoline powered RC helicopters, often called simply *gassers*, are relatively rare.



Century Predator Gasser helicopter top and to the left. Zenohu Z231HB gasoline engine middle right.

RC Helicopter Components

Electric Power

- The alternative to internal combustion power is electric power (EP).
- Where IC power systems have fuel tanks and engines, electric power systems have *batteries* and *motors*.*
- The technology for electrically-powered RC aircraft has improved significantly over recent years and continues to advance.
- Similar to glow-fuel helicopters, electric helicopters tend to fly for 5 to 20 minutes† on one battery charge.

* This usage of the terms “engine” and “motor” is a convention used in this presentation, but it is not universally followed.

† The flight time from one charge depends on multiple factors; your flight time will vary. Twenty minutes is very high.

RC Helicopter Component

Electric Power: Key Terms

- Electric power comes from moving charge.
 - Charge is a property of particles like electrons.
 - Electrons are atomic particles that can move through some materials such as metals quite easily.
- Voltage (V) is...
 - a measure of electrical pressure, that is how strongly charge is driven to move.
 - measured in volts (V).
- Current (I) is...
 - a measure of how much charge is moving in a given period of time.
 - measured in amperes (A).
- While power (P) of internal combustion systems is usually measured in horsepower (hp), electric power is usually measured in watts (W).
 - $1 \text{ hp} \approx 746 \text{ W}$
 - Electric power increases when voltage or current (or both) increase.

RC Helicopter Components

Electric Power: Cells and Batteries

- Batteries are collections of storage *cells*.
 - Often the term battery is incorrectly used for what is really a cell.
 - Something like a round, 1.5V AA flashlight battery is actually a single cell.
- A cell can store charge and then deliver it at a certain voltage (or electrical pressure).
- A cell also has a limit on the maximum current (or amount of charge in a given length of time) it can deliver.
- One key differentiation among cells is their chemistry, such as...
 - Nickel based
 - Lithium based
- The four cell types most commonly found in RC aircraft models are: *
 - NiCd: Nickel Cadmium
 - NiMH: Nickel Metal Hydride
 - LiPo: Lithium Polymer
 - LiIo: Lithium Ion
- All cell types may be combined into batteries in two ways:
 - in series
 - in parallel

* Some aircraft modelers are experimenting with a fifth type, relatively new LiFe cells also sold as A123 cells.

RC Helicopter Components

Electric Power: Series, Parallel Cells



Model Helicopter Insights™
RC Helicopter Primer

- With cells in series, the voltages add up.
 - One cell: 1V, 1A max
 - Battery: 2V, 1A max
- With cells in parallel, the currents add up.
 - One cell: 1V, 1A max
 - Battery: 1V
 - 2A max or...
 - 1A for twice as long
- Series and parallel can also be combined for more complex batteries.

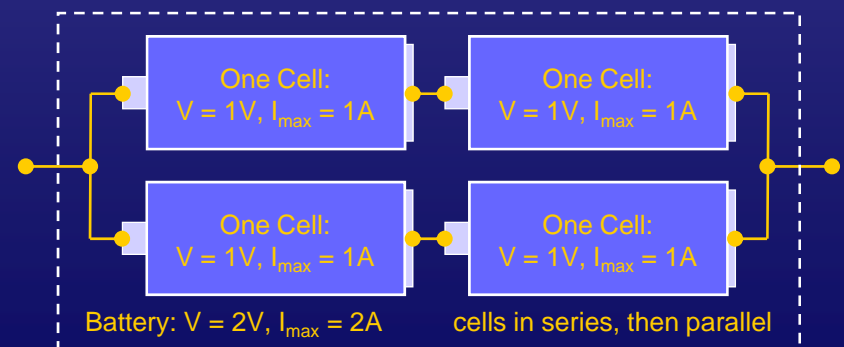
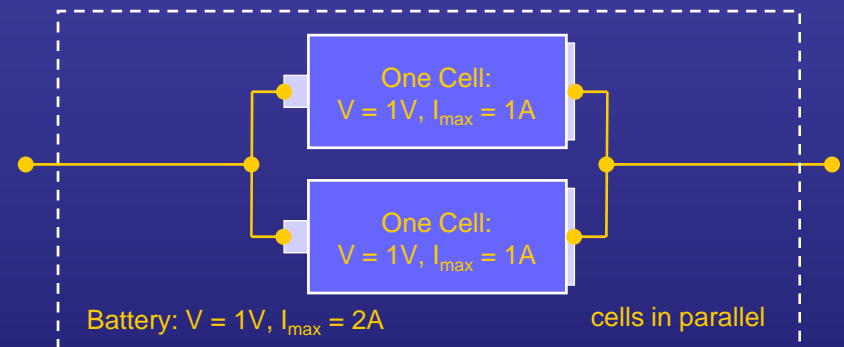
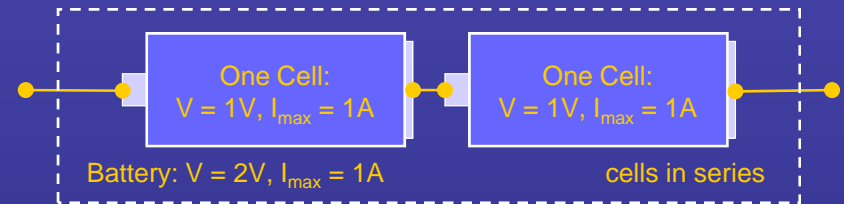

RC Helicopter Components

Electric Power: Ni and Li Cells

- A given electric helicopter will be designed for a particular cell count.
- Such a cell count...
 - historically refers to the number of nickel-based storage cells, NiCd or more often NiMH cells, in series.
 - is equivalent to a maximum operating voltage...
 - where each nickel cell has a nominal voltage of 1.2V.
 - so a 10-cell helicopter, for example, is intended to run on (approximately) 12V.
- Another type of cell is a lithium polymer or LiPo cell.
 - A LiPo cell has a nominal voltage of 3.7V.
 - One LiPo cell (3.7V) is roughly equivalent to three nickel cells in series ($3 \times 1.2V = 3.6V$).
- LiPo battery packs often carry a xSyP designation...
 - where x = cell count in series, y = cell count in parallel.
 - so 4S2P, for example, means four cells in series and then two sets of four cells in parallel for a total of eight cells.



RC Helicopter Components

Electric Power: NiCd vs NiMH

- NiCd and NiMH cells and batteries are similar but do have some differences.
- Relative to NiCd cells, NiMH cells have...
 - higher capacities (i.e. can store more energy).
 - higher self-discharge rates (i.e. drain faster while sitting on the shelf).
 - higher internal resistances (i.e. are potentially less suited for high-current applications).
 - are more likely to be damaged by accidental overcharge and heat.
- NiCd cells are often used in batteries that power the radio receivers in RC aircraft.
- NiMH cells have been used for batteries that power the motors in electric helicopters, although LiPo technology has overtaken NiMH in this application.

RC Helicopter Components

Electric Power: Ni/Li Tradeoff



Model Helicopter Insights™
RC Helicopter Primer

- NiCd and NiMH batteries...
 - provide 1.2V per cell.
 - use round (cylindrical) cells.
 - are rechargeable.
 - are less expensive.
 - are more durable (i.e. less prone to damage during crashes)
 - tend to weigh more.
 - provide less capacity.
 - lower maximum currents.
 - shorter run times.
 - can be charged using simple chargers (although a fancy charger is still desirable).
- LiPo batteries...
 - provide 3.7V per cell.
 - use flat-pack cells.
 - are rechargeable.
 - are more expensive.
 - are less durable (i.e. more prone to crash damage)
 - tend to weigh less.
 - offer higher capacity.
 - higher maximum currents.
 - longer run times.
 - require special chargers.
 - need to be handled with care or they can start a fire.



Left: one eight-cell nickel-metal-hydride (NiMH) battery pack.



Right: Evo FlightPower three-cell lithium polymer (LiPo) battery pack (left), two different Tanic LiPo packs (middle), Thunder Power three-cell LiPo battery pack (right).



RC Helicopter Components

Electric Power: Battery Capacity

- In addition to cell count and voltage, rechargeable cells and batteries are marked with capacity ratings.
- Capacity is typically specified in milliamp-hours (mAh).
 - A 1000 mAh cell, for example, can supply a current of 1000 mA or 1 A for 1 hour (approximately).
 - This per-hour current is typically abbreviated as the “C” factor of the cell or battery.
 - If the 1000 mAh cell is discharged at a current of C/10 (i.e. 100 mA) then it will last for 10 hours (approximately), and so on.
- Recall that currents add in parallel cell configurations.
 - Two 1000 mAh cells in parallel provide 2000 mAh of capacity.
 - Three 500 mAh cells in parallel provide 1500 mAh of capacity.

RC Helicopter Components

Electric Power: Battery Discharge



Model Helicopter Insights™
RC Helicopter Primer

- Batteries also have maximum discharge rates which are typically specified as multiples of C.
- Trying to discharge the battery above the specified maximum rate...
 - will result in poor battery performance.
 - may damage the battery, especially in the case of lithium-based batteries.
- For example, if a battery...
 - is rated at 640 mAh and 15C maximum discharge rate.
 - the maximum discharge current is:
 $15 \times 640 \text{ mA} = 9600 \text{ mA} = 9.6 \text{ A}$.
- Flight power (i.e. motor) batteries should have sustainable maximum discharge rates of at least 10 C,* and more is better (and required for aggressive aerobatic flying).
 - LiPo batteries used as flight power batteries should have explicit and appropriate maximum discharge ratings.
 - NiMH batteries are more forgiving and should be safe to use even if they don't have maximum discharge specifications.



Left: label from a small 3S1P LiPo battery from ElectriFly.

* This statement is intended as a rough guideline only; actual numbers depend on the specifics of the helicopter.

RC Helicopter Components

Electric Power: Electric Motors

- The flight battery will (indirectly) drive an electric motor.
- Electric motors come in two varieties: *brushed* and *brushless*.
- “Brushed” and “brushless” refer to differences in the motors’ internal construction.*
- Brushless motors also come in *in-runner* and *out-runner* varieties, a distinction that’s not critical at this point.



Above: three brushed motors

* How brushed and brushless motors differ in internal construction and operation is beyond the scope of this presentation.



Above: NEU (top left) Align 400LF (middle), Astro 020 803T (top right), Plettenberg Orbit (bottom left), Hacker C50-series (bottom right)

RC Helicopter Components

Electric Power: Brushed/Brushless

- Brushed motors...
 - have two connection wires.
 - have parts, the brushes, that wear out, eventually causing such motors to fail.
 - work with simple (or possibly no) control electronics.
 - are less power efficient.
 - are less expensive.
 - may be found in small electric helicopters.
- Brushless motors...
 - have three connection wires.
 - have no brushes that wear out, thereby offering longer overall operating lives.
 - require advanced electronic controllers.
 - are more power efficient.
 - are more expensive.
 - are the motors of choice for all but the smallest electric helicopters.

RC Helicopter Components

Electric Power: Motor Specs

- Electric motors have multiple technical characteristics or specifications, such as...
 - kV: the motor's *speed constant* specified in rotations-per-minute-per-volt (RPM/V)
 - I_0 : the current the motor consumes while it's running with no load
 - R: the electrical resistance of the motor's internal wire windings
 - m: the motor's mass (or weight)
- The kV constant...
 - is the most prominent parameter.
 - allows the maximum (unloaded*) motor speed to be calculated.
 - Assume 12 NiMH cells = $12 \times 1.2V = 14.8V$
 - Assume motor kV = 1,500 RPM/V
 - Then maximum motor speed is – $14.8 V \times 1,500 \text{ RPM/V} = 22,200 \text{ RPM}$

* The maximum motor speed obtained here is an unloaded speed. If the motor is loaded, that is if it actually has to deliver power to something like a helicopter's rotor, the maximum speed will be lower.

RC Helicopter Components

Electric Power: Gears

- The example motor speed was 22,000 RPM, but depending on helicopter size and flying style, rotor speeds tend to be...
 - in the range of 1400 to 3000 RPM (or sometimes even more).
 - more typically between 1600 and 2600 RPM.
- So the motor speed is much higher than the rotor speed.
- The motor drives the helicopter's main rotor through a set of gears that reduce the motor speed to the rotor speed.
 - The gear attached directly to the motor is the *pinion gear*.
 - The pinion gear in turn drives the *main gear*, and the main gear directly drives the main rotor shaft.
- Most helicopters have only a single gear stage (pinion to main), although some have two (pinion to intermediate to main).

RC Helicopter Components

Electric Power: Pinion Gear (1)

- The number of available main gears for a helicopter is often just one, so the number of main gear teeth is fixed.
- The motor pinion is almost always changeable, so the overall gear ratio is adjustable.
- The typical electric helicopter will have three, five or more pinion gear options, with the proper choice depending on...
 - the battery being used (i.e. the series cell count and resulting voltage).
 - the kV of the chosen motor.
 - the desired rotor speed.

RC Helicopter Components

Electric Power: Pinion Gear (2)

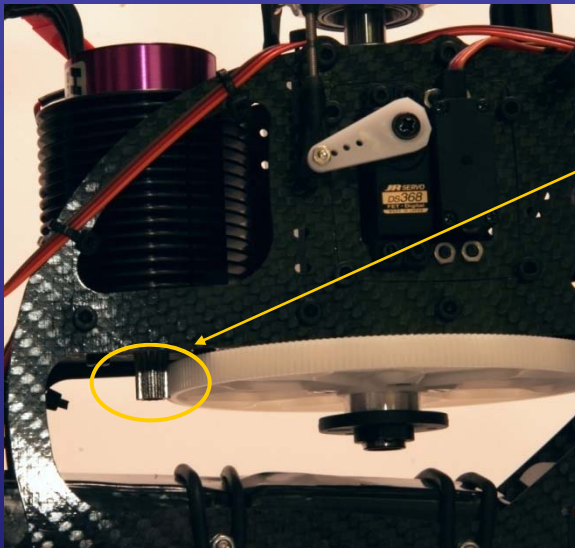

Pinion Gear (silver) on
Motor Shaft driving
Main Gear (white)

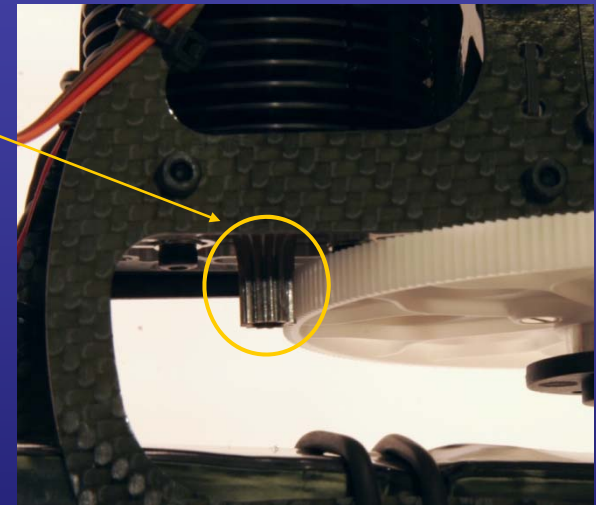

Above and to the right: Mikado Logo 10
Carbon helicopter with Hacker B50-series
brushless motor (Photo by W. Witt)

The example pictures above are from a Logo 10 Carbon helicopter. This helicopter's main gear has 200 teeth, and available pinion gears range from 13 to 23 teeth, providing gear ratios from 1:15.4 to 1:8.7.

RC Helicopter Components

IC Power Flashback: Gears



Model Helicopter Insights™
RC Helicopter Primer

- Recall that the section on internal combustion power did not include a discussion on pinion gears and gear ratios.
- With glow engines, in contrast to electric power systems, ...
 - optimal engine speeds are naturally much more consistent across different engines (i.e. no battery and kV variation).
 - 30 to 50-class engines: approximately 17,000 to 18,000 RPM
 - 60 to 90-class engines: approximately 15,000 to 16,000 RPM
 - glow-fuel helicopters have relatively limited gear choices or may even have fixed gear ratios.
- Thunder Tiger's Raptor 90 helicopter, for example, offers a relatively large set of gearing options.

Raptor 90 Gear Ratio Options		Main Gear Teeth			
		91	93	94	95
Pinion Gear Teeth	10	9.1:1	9.3:1	9.4:1	9.5:1
	11	8.27:1	8.45:1	8.54:01	8.64:1
	12	7.58:1	7.75:1	7.83:1	7.91:1

RC Helicopter Components

Electric Power: Many Choices (1)

- Choosing a good battery/motor/pinion combination can be a daunting task, as the number of possible combinations is quite large (larger than the equivalent selection of glow engines).
- The large selection of electric power system components and their characteristics...
 - provides a lot of flexibility and many options to optimize a helicopter...
 - for one style of flying or the other.
 - for a particular budget.
 - makes it easy to get very confused.
- Making this selection is somewhat analogous to tuning a glow engine except that it happens before the helicopter is built.

RC Helicopter Components

Electric Power: Many Choices (2)

- The good news is that...
 - manufacturers often recommend certain battery, motor and pinion combinations for their helicopters.
 - dealers frequently sell helicopter packages that include suitable power system components.
- Below are two examples of electric power system recommendations found in helicopter manuals.

Right: manufacturer's recommendations for Century Swift 16 helicopter

Below: manufacturer's recommendations for Align T-Rex 450XL

POWER SYSTEM REQUIRED FOR ASSEMBLY

Motor Gear Ratio:

	General flight	3D Flight
4000-4200KV	9T	9T
3500-3800KV	11T	11T
2800-3200KV	13T	13/15T
2300-2500KV	13T	15T



400 Brushless Motor



Lithium Battery DC11.1V
 (Discharge Current: 15A and more)

Mechanical Specs:

Main Rotor Blades: 520-550mm

Tail Rotor Diameter: 21cm

Length: 105cm

Height: 34.4cm

Weight: 1.54kg (configured with brushless motor and servos)

Electronic Specs:

Speed Control: 50-80 Amp

Motor: 900-1250kv (based on battery)

Battery: 4S-6S Li-Po or 12 cell NiMH or NiCd

Pinion: 9-15 tooth

Head Speed: 1600-2100 RPM

RC Helicopter Components

Electric Power: Speed Controllers

- Operating an electric motor in a radio controlled model requires an *electronic speed controller (ESC)*.
- An ESC...
 - is a small electronic device.
 - interprets a signal from the radio receiver.
 - controls the motor, such that it runs at the required speed.
- Brushed and brushless motors require different types of ESCs.
- Brushless ESCs are more sophisticated than the brushed variety.

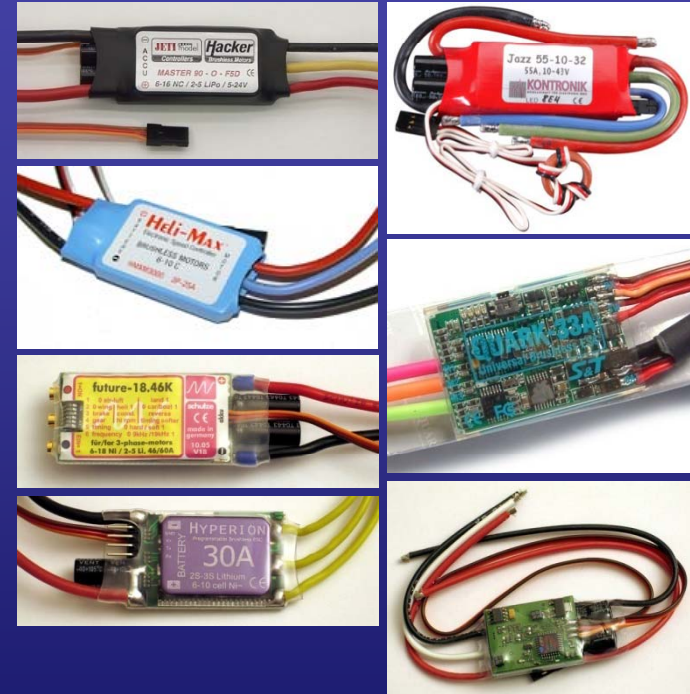

Group at top right: brushless ESCs: Hacker (top left), Heli-Max (top middle left), Schulze Future (bottom middle left), Hyperion (bottom left) Kontronik Jazz (top right), Quark (middle right), Castle Creations Phoenix (bottom right)

Group at bottom: brushed ESCs: Castle Creations Pixie (left), Telebee (middle), Speed Max (right)

RC Helicopter Components

Electric Power: ESC Current Ratings



Model Helicopter Insights™
RC Helicopter Primer

- ESCs have maximum current ratings (similar to batteries' maximum discharge ratings).
 - An ESC for a micro-helicopter may need to be rated for 10A* of continuous current.
 - An ESC for a mid-size helicopter may need to be rated for 60A.*
- An ESC's maximum sustainable current is different from its maximum peak current.
 - Momentary peaks will exceed the sustained maximum.
 - Some ESCs specify the two values separately.
 - If only one value is specified, it is typically the sustainable maximum.†



Above: Castle Creations Phoenix ESCs of different current ratings (10A through 80A)

* These numbers are only approximate examples. Actual currents will depend on several factors, such as motor and battery choice, target rotor speed and flying style.

† Don't count on this statement being true. Check the documentation of your specific ESC.

RC Helicopter Components

Electric Power: ESC Current Margin

- Helicopters tend to present high-stress* environments to ESCs...
 - so choosing an ESC that provides current margin is often beneficial.
 - such that if the maximum expected sustained current is 25A, a 35A ESC may be a good choice.
- ESCs with heat sinks may be required for...
 - large models.
 - models set up for aggressive aerobatic flying (i.e. 3D flying).
- When an ESC is overstressed...
 - it may have a heat-related failure.
 - in an extreme case, it may catch fire.

* For example, the advertised current capacity may assume a certain airflow over the ESC, but when the ESC is mounted under a helicopter's canopy, such airflow may not be present.

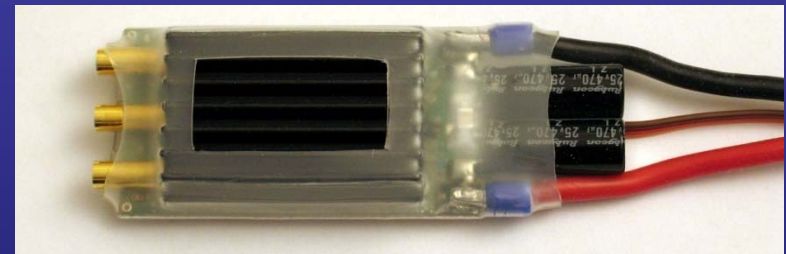

Above: Schulze 46/60A ESC (with black heat sink on back) (Photo by W. Witt)

Bottom: Century Electron 50/77A ESC (left) and 80/100A ESC (right)



RC Helicopter Components

Electric Power: ESC Features

- An ESC for a helicopter should have certain specific features:
 - Slow start (not to strip gears)
 - No brake (to allow for auto-rotations)
 - Governor mode (nice but not required; more about governors later)
 - Soft cut-off if the battery voltage gets too low (nice but not required)
- Many ESCs can be programmed for different applications (e.g. airplane or helicopter) either by...
 - setting small switches on the ESC.
 - moving the throttle stick on the transmitter through special programming sequences.
 - connecting the ESC to a computer through a custom interface and special programming software.

RC Helicopter Components

Electric Power: ESC Differences

- In general, different makes and models of ESCs will differ in the following ways:
 - What the maximum battery cell counts or input voltages can be.
 - How much motor current they can handle (sustained and peak amps).
 - How well their rated current capacities correspond to their actual capabilities.
 - What applications they're suited for (helicopter, plane, car, boat).
 - Whether they have a governor feature, and how well that feature works.
 - How programmable they are (e.g. motor timings, governor control loop gain).
 - How easy they are to program.
 - Whether they have built-in voltage regulators or BECs,* and what the current capacities of these regulators are.
 - Whether they're manufactured from high-quality electronic components.
 - Whether their firmware (on-board control software) is upgradeable.
 - How large they are and how much they weigh.
- Cheap ESCs are often cheap for a reason (i.e. their quality may be relatively low).
- With a cheap ESC or an ESC included in a kit...
 - actual current capacity may not measure up to rated capacity.
 - the governor feature may not work well.

* Voltage regulators and BECs are discussed more on later slides.

RC Helicopter Components

Power Systems: IC/EP Tradeoffs (1)



Model Helicopter Insights™
RC Helicopter Primer

- Internal Combustion Power:
 - Available for mid-range to large helicopters.
 - Helicopter is noisy due to engine sounds.
 - Relatively few engine choices are available for a given size helicopter.
 - Engines require break-in periods.
 - Fuel/air mixture needs to be tuned, and getting an engine to behave consistently can sometimes be difficult.
 - The power system is typically less expensive.
 - Glow engine + throttle servo (+ muffler) †
 - Low incremental fuel costs
 - Short time between consecutive flights: refuel and fly again (as long as receiver battery remains sufficiently charged).
- Electric Power:
 - Available for small to mid-range helicopters. *
 - Helicopter is relatively quiet.
 - Many types of motors and speed controllers are available.
 - No special break-in required, just go fly.
 - Motor kV, gear ratio and battery parameters need to be selected carefully, but once set correctly, they keep working.
 - The power system is typically more expensive.
 - Motor + ESC
 - High up-front battery cost
 - Possibly longer time between consecutive flights: flight (motor) battery needs to be recharged; multiple batteries are required for back-to-back flights.

* Some large electric helicopters are available, but they are relatively rare and expensive.

† A kit may or may not include a basic muffler; a high performance muffler typically has to be purchased separately.

RC Helicopter Components

Power Systems: IC/EP Tradeoffs (2)



Model Helicopter Insights™
RC Helicopter Primer

- Internal Combustion Power (cont):
 - The engine is a source of vibration.
 - Fuel and oil residues need to be cleaned up after flying.
 - More parts require maintenance (glow plugs, fuel lines, engine bearings).
 - Not a likely source of electrical disturbances.
 - Gear ratios are fixed or options are relatively limited (and rarely needed).
 - Requires clutch mechanism (so the rotor does not turn while the engine is idling).
 - More support/field equipment is required.
 - Fuel jug and fuel pump
 - Glow plug heater/driver
 - Starter with battery (12V to 24V)
 - Spare glow plugs
 - Cleaning supplies
- Electric Power (cont):
 - The motor is not a source of vibration.
 - No fuel or oil to clean up.
 - Very little maintenance is required.
 - More likely to cause electrical disturbances (glitches) in the radio control system.
 - Gear ratios are typically easily customized (by changing the pinion gear).
 - No clutch mechanism required (motor can stop and start on demand).
 - Less support/field equipment is required.
 - Motor batteries
 - Battery charger
 - Large 12V battery (typically lead-acid; car battery may be ok) to power the charger at the field

RC Helicopter Components

Power Systems: IC/EP Tradeoffs (3)



Model Helicopter Insights™
RC Helicopter Primer

- Internal Combustion Power (cont):
 - Fuel tank can easily be monitored for the amount of remaining fuel.
 - Nothing really bad happens if a fuel tank is filled until it overflows or is drained until it is dry.
 - Engine performance should not degrade significantly over time (if the engine is properly tuned and maintained).
 - Power system tends to have slightly poorer response to abrupt maneuvers (i.e. slower acceleration, less “pop”), but power tends to be consistent as fuel tank drains.
 - An engine speed sensor needs to be installed to run with a speed governor. *
 - No soldering work required.
- Electric Power (cont):
 - Observing the amount of charge remaining in a battery is more difficult (especially from a distance).
 - Batteries may be damaged (and some lithium batteries may catch fire) if over-charged or over-discharged.
 - Battery performance degrades slowly as a battery ages.
 - Power system tends to respond better to abrupt maneuvers (i.e. offers quicker acceleration, has better “pop”), but power tends to drop as battery discharges.
 - No special sensor is required to operate with a speed governor (as long as the ESC has a governor feature). *
 - Assembling the power system may require soldering work.

* Governors are discussed more on later slides.



RC Helicopter Primer

RC Helicopter Component Details

Power Systems

Servos

Helicopter Kits

Gyros

Governors

Automatic Mixture Controllers

Transmitters and Receivers

BECs / Voltage Regulators

Multi-Function Modules

Tools and Equipment

RC Helicopter Components

Servo Motors



Model Helicopter Insights™
RC Helicopter Primer

- A servomotor or *servo* is a device that...
 - consists of...
 - an electric motor that's driving a set of gears that then drive an *output shaft* or *spline*.
 - a electronic circuit with connections for power and motor control.
 - works by...
 - interpreting a control signal.
 - moving the motor to the position dictated by that signal.
 - actively holding that position until the control signal is changed.
 - is used to move a piece of a larger mechanism (e.g. the swash plate) to a desired position.
- Different servomotors with various characteristics are available for different applications.



Above: HiTec HS-525BB servo (top), JR DS368 servo (middle), Futaba S9001 servo (bottom)

RC Helicopter Components

Servos: Servo Arm Motion

- An arm (or horn) attaches to a servo's shaft to...
 - provide a point to connect the mechanism that needs to be controlled.
 - often translate rotary motion into more linear motion.
- The range of rotation is typically around 90° to 120° (45° to 60° in either direction from a center position).
- Servo arms or horns...
 - come in different shapes for different applications.
 - frequently have a number of pre-drilled holes to attach ball links and push rods.

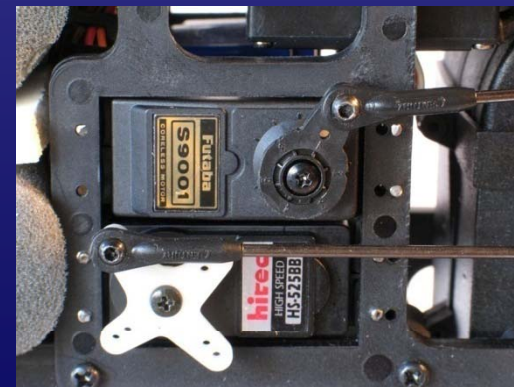

Above: Hitec HS-6975HB digital servo (left) and assorted servo arms (right)

Left: Two servos installed in a helicopter

(Photos by W. Witt)

RC Helicopter Components

Servos: Installation Examples

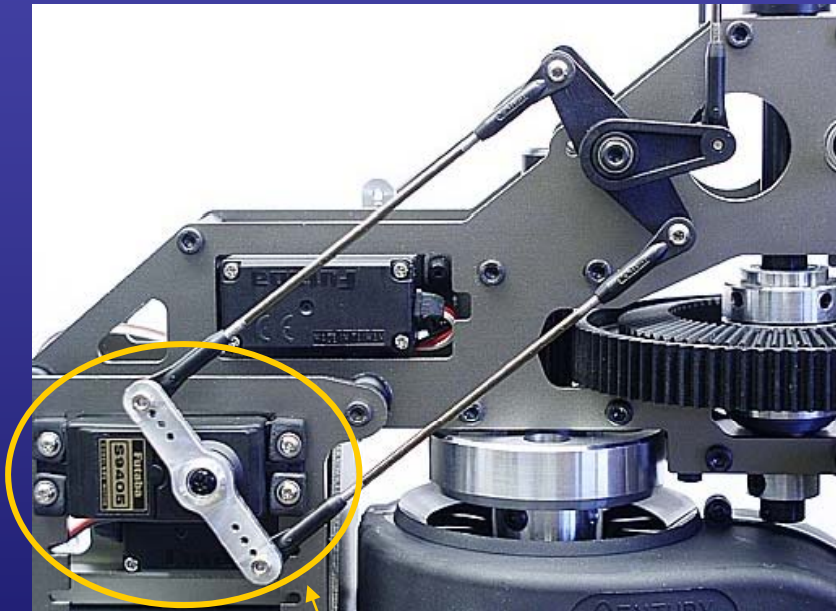

Above: Century Predator 60 helicopter

Servo attached to swash plate mechanism through two control links in a push/pull configuration.



Above: Century Hawk Pro helicopter (Photo by W. Witt)

Collective pitch servo (top) and engine throttle servo (bottom).

RC Helicopter Components

Servos: Servo Characteristics (1)



Model Helicopter Insights™
RC Helicopter Primer

- Servos are available from numerous manufactures and each manufacturer offers a range of servos with different characteristics for different applications:
- Size and mounting hole pattern: micro, mini, standard, etc.
 - Unfortunately, these designations are not used consistently.
 - Even when two servos are in the same size class, they...
 - are not necessarily identical in size.
 - do not necessarily have identical mounting hole patterns.
 - Review a servo's detailed size specs before buying it.
- Strength or torque: amount of holding power (usually measured in oz·in or kg·cm, where $1 \text{ kg}\cdot\text{cm} \approx 13.9 \text{ oz}\cdot\text{in}$)
- Speed or transit time: time (usually in seconds) for an unloaded servo arm to sweep through an angle (usually 60°)

RC Helicopter Components

Servos: Strength and Speed

- Strength (torque) and speed (transit time) are two key servo characteristics.
- One of these properties must often be traded off against the other.
 - More strength, less speed.
 - More speed, less strength.
- Strength and speed increase with increasing operating voltage.
 - The typical operating voltage is 4.8V (or 5.0V), but many servos can also operate at 6.0V (or maybe more).
 - Futaba S9001 example:
 - 4.8V: 54.1 oz in, 0.22 sec/60°
 - 6.0V: 72.2 oz·in, 0.18 sec/60°

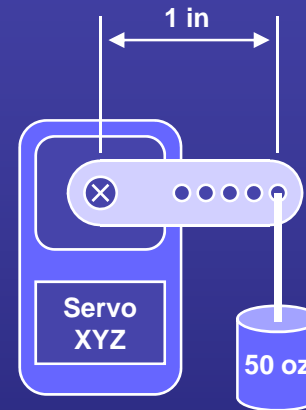

Servo Strength: A servo that can hold up to 50 oz with an arm of 1 in has 50 oz·in of holding power or torque. 50 oz·in is also equivalent to holding 25 oz with a 2 in arm, and so on. Torque values range from less than 10 to more than 200 oz·in.

Servo Speed: The speed is typically specified as the time an unloaded servo arm takes to travel through 60° of arc. Speeds typically range from 0.05 to 0.50 sec/60°.

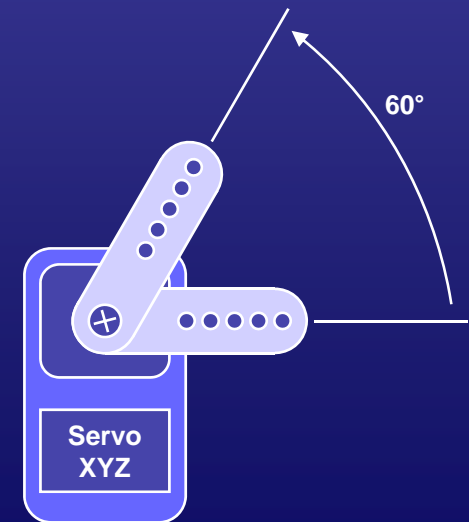

RC Helicopter Components

Servos: Servo Characteristics (2)

- Different characteristics for different applications (cont):
- Positioning precision (sometimes called centering ability): how reliably and repeatedly the servo mechanism moves exactly to the commanded position (i.e. the inverse of positioning error)
- Type of control electronics: analog or digital
 - Digital servos are the newer technology.
 - They offer...
 - faster speeds.
 - crisper response.
 - higher torques.
 - increased positioning precision.
 - On the other hand, they...
 - are more expensive than analog servos.
 - consume more power (i.e. require better batteries).
 - Analog servos still perform well in many applications.

RC Helicopter Components

Servos: Servo Characteristics (3)

- Different characteristics for different applications (cont):
- Gear material: nylon, metal, etc.
 - Many servos use nylon gears; they are relatively light and sufficiently strong for most applications.
 - Metal gears provide additional strength (i.e. are harder to break), but they are relatively heavy, and with use, the metal tends to deform slightly, increasing the amount of play in the gear train.
 - Additional high-end materials are available, such as karbonite or titanium.
- Motor type: cored or coreless brushed motor, or brushless motor
 - Cored motors are less expensive.
 - Coreless motors offer faster response times and possibly greater torques.
 - Brushless motors advertise even faster response times, smoother operation and increased resistance to damage from vibration (e.g. from an IC engine).
- Weight: how much the servo weighs (strongly affected by the gear type)

RC Helicopter Components

Servos: Servo Characteristics (4)

- Different characteristics for different applications (cont):
- Bearings: how many ball bearings (as opposed to bushings) the servo includes primarily to guide its main shaft or spline
 - Bearings are more expensive, but provide for smoother shaft movement.
 - Bushings wear more over time, resulting in increased play in the servo shaft.
- Mechanical play or slop: how much the servo shaft is free to move while the servo mechanism is actively holding a position (affected by use of bushings vs. bearings, gear type and gear precision)
- Pulse width: control signal timing required by the servo electronics
 - 1500 μ s pulse for center position for analog and normal digital servos
 - less (e.g. 750 μ s) for special digital servos (e.g. for gyro use)

RC Helicopter Components

Servos: Servo Requirements

- An IC-powered collective-pitch helicopter requires five servos:
 - Collective pitch
 - Fore/aft cyclic pitch (elevator)
 - Right/left cyclic pitch (aileron)
 - Tail rotor pitch (rudder)
 - Engine throttle
- An electric collective pitch helicopter requires four servos:
 - Collective, elevator, aileron and rudder as before.
 - The throttle function is performed electronically in the ESC, so a throttle servo is not required.
- The types of servos that should be used for a helicopter depend on the helicopter in question.
 - Helicopter size
 - Pilot's flying style (e.g. sport flying or aerobatics)
 - Pilot's budget

RC Helicopter Components

Servos: Rough Guidelines (1)



Model Helicopter Insights™
RC Helicopter Primer

- Collective pitch servo: *
 - 60 to 100 oz·in (stronger is ok)
 - 0.25 to 0.15 sec/60° (faster is ok)
- Cyclic pitch servos: *
 - a little less torque than collective is ok as the cyclic servos bear less load
 - a little more speed than the collective, up to 0.10 sec/60°, may be nice for crisper cyclic response rate
- Throttle servo:
 - torque can be low; about 20 to 30 oz·in should be enough as the engine's throttle arm is easy to move
 - should be faster than collective servo, maybe around 0.15 to 0.10 sec/60°, so engine power can lead rotor disc load during climbs

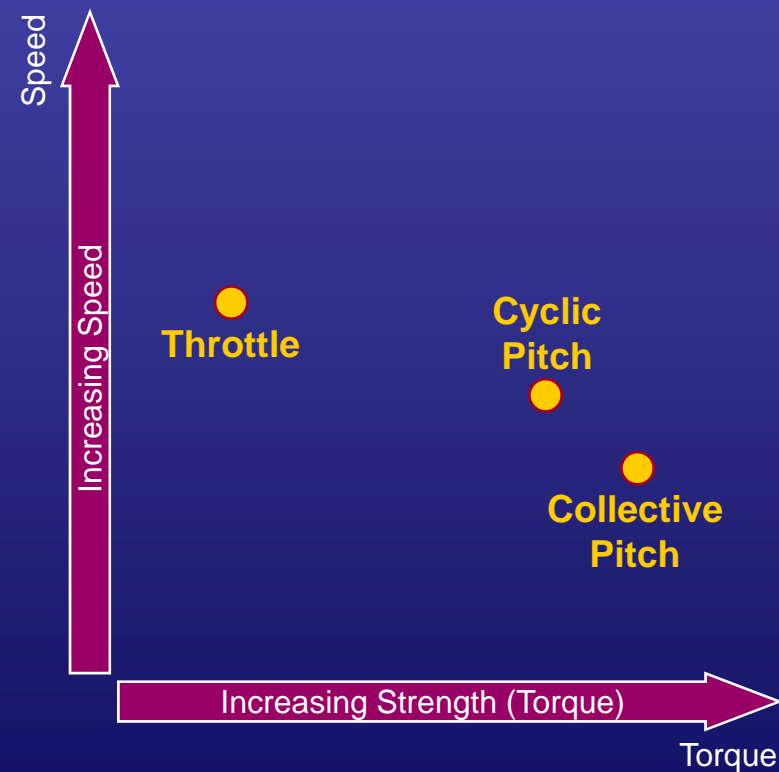

* For very aggressive aerobatic maneuvers, more torque and speed would be needed. At the time of this writing, a popular (and expensive) high-end swash plate (i.e. collective and cyclic pitch) servo offers 0.90 sec/60° and 160 oz·in of torque at 4.8V.

RC Helicopter Components

Servos: Rough Guidelines (2)



Model Helicopter Insights™
RC Helicopter Primer

- Tail pitch servo:
 - speed is important to maintain a stable tail (more in gyro section later); should be at least 0.10 sec/60° and faster is better
 - torque is less critical; about 40 oz·in should be ok
- A digital servo for the tail is typically worth the money; analog servos are adequate for all other functions.

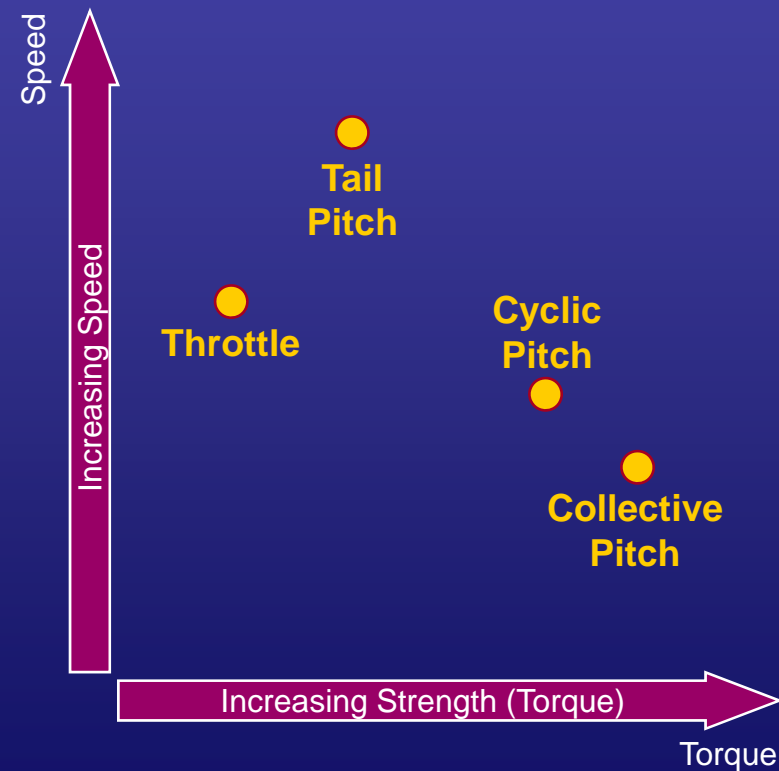

RC Helicopter Components

Servos: Rough Guidelines (3)

- The two previous slides provide only a rough guide to servo characteristics for a typical, roughly 30- or 50-size,* entry-level to intermediate helicopter.
 - Servos with less torque are ok for micro or mini helicopters.
 - More torque may be required for swash plate control in larger helicopters.
 - Faster and stronger servos may be needed for aggressive aerobatic flying.
- If needed, consult an experienced builder to get more specific recommendations.
- Radio transmitters often come with sets of four identical servos for collective, cyclic and throttle.
 - Such a servo set can work fine.
 - Identical servos for collective and cyclic are ok.
 - The behavior of a faster throttle servo can be adequately emulated.
 - Within limits, different speed/torque characteristics can be achieved through different servo arm lengths and associated radio transmitter programming. †

* More on helicopter sizes later.

† Details on how to trade off servo speed and torque through servo arm selection are beyond the scope of this presentation.



RC Helicopter Primer

RC Helicopter Component Details

Power Systems

Servos

Helicopter Kits

Gyros

Governors

Automatic Mixture Controllers

Transmitters and Receivers

BECs / Voltage Regulators

Multi-Function Modules

Tools and Equipment

RC Helicopter Components

Helicopter Kits

- Many different types of helicopter kits are available and can accommodate different...
 - interests.
 - budgets.
 - skill levels.
 - other constraints, such as available flying area.
- The following slides provide an overview of...
 - major helicopter attributes.
 - some related considerations.

RC Helicopter Components

Helicopter Kits: Kit Contents

- Frame
 - Engine or motor mount
 - Fuel tank or battery tray
 - Drive gears
 - Parts of the rotor control mechanics
 - Mounts for the avionics
- Main rotor head and rotor
 - Swash plate
 - Pitch compensator or washout hub
 - Control linkages
 - Fly bar and paddles
 - Rotor blade grips and blades
- Tail
 - Tail boom with boom supports
 - Tail rotor
 - Vertical and horizontal fins
- Landing gear, skids
- Canopy
- An engine or motor is sometimes included in a kit while the avionics are typically not included, although package deals are sometimes available.



All four sample pictures here show a Century Falcon 50-size helicopter.

RC Helicopter Components

Helicopter Kits: Characteristics



Model Helicopter Insights™
RC Helicopter Primer

- Main rotor type
 - Fixed pitch
 - Collective pitch
- Power source options (previously covered)
 - Internal combustion (IC) power
 - Electric power (EP)
- Model helicopter sizes
 - Micro
 - Mini
 - 30 to 50 size
 - 60 to 90 size
- Pitch mixing type
 - Mechanical mixing (mCCPM)
 - Electronic mixing (eCCPM)
- Performance parts
 - Carbon parts
 - Metal parts
 - Ball bearings
- Additional considerations
 - Build types
 - Manuals
 - Replacement parts

RC Helicopter Components

Kit Characteristics: Rotor Type (1)

- Recall the helicopter discussed during *Basic Principles of Operation...*
- With that type of helicopter, varying amounts of lift are generated by...
 - spinning the rotor disc at a constant speed.
 - varying the rotor blades' angle of attack.

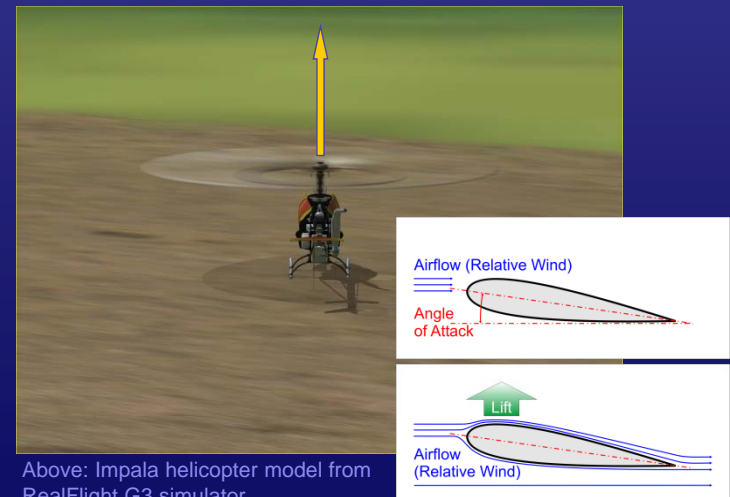
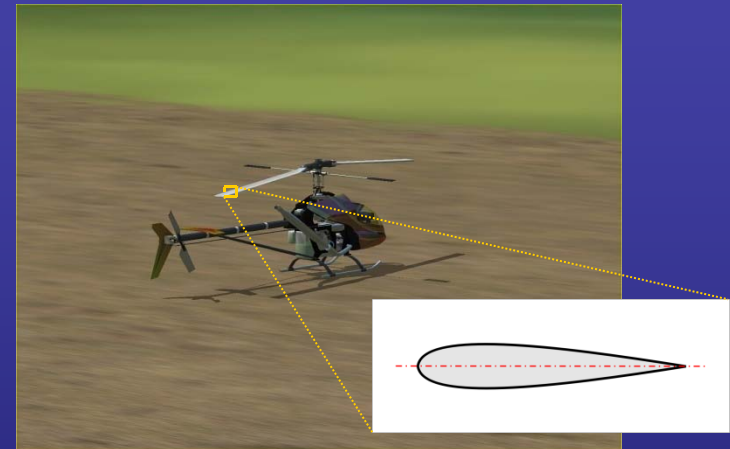

Above: Impala helicopter model from RealFlight G3 simulator

RC Helicopter Components

Kit Characteristics: Rotor Type (2)

- Also recall that, in general, lift increases when...
 - the rotor blade's angle of attack increases.
 - the speed of the relative wind increases.
- A *collective pitch* helicopter varies lift by...
 - keeping the rotor speed constant.
 - varying the blade pitch (i.e. the angle between a blade and the rotor disc) and thereby varying the angle of attack.*
- Alternatively, a *fixed pitch* helicopter varies lift by...
 - using a rotor blade arrangement of a constant, unchangeable pitch.
 - varying the rotor speed and so the speed of the relative wind.

* While the pitch angle affects the angle of attack, the two angles are not necessarily the same.

RC Helicopter Components

Kits: Rotor: Fixed Pitch (1)

- A fixed pitch helicopter's rotor blades are, by definition, fixed at a positive pitch.
 - A fixed pitch helicopter may be identified by...
 - a swash plate that...
 - uses only two control servos, one for each cyclic control.
 - can only tilt and cannot move up or down.
 - rotor blades that...
 - have asymmetrical cross sections.
 - are wider near the rotor head and narrower near their tips.
- Since a fixed pitch rotor blade is always at positive pitch, its shape is optimized to maximize lift for upright flight.

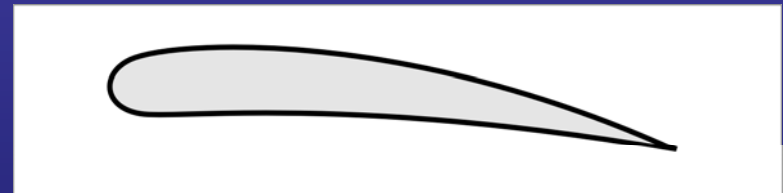

Asymmetrical Rotor Blade for Fixed Pitch Helicopter not capable of Inverted Flight

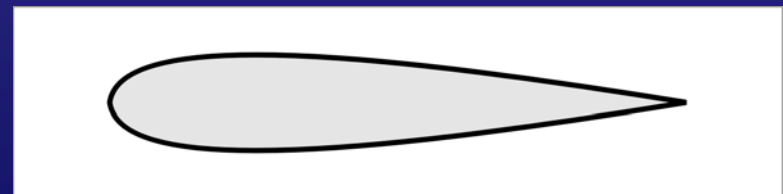

Symmetrical Rotor Blade for Collective Pitch Helicopter capable of Inverted Flight

RC Helicopter Components

Kits: Rotor: Fixed Pitch (2)

Fixed pitch helicopters:



Above: Lite Machines Corona 120 helicopter (left), Century Hummingbird Elite FP helicopter (right)

Collective pitch helicopters:

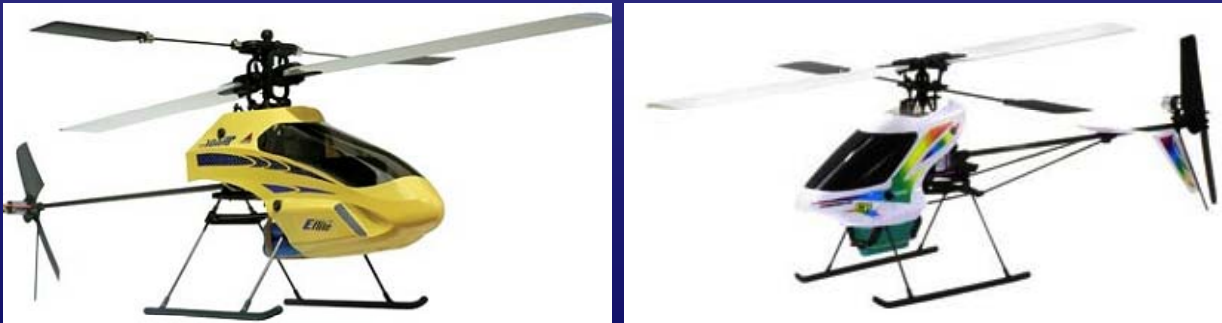

Above: E-Flite Blade CP helicopter (left), Century Hummingbird Elite CP helicopter (right)

Note the differently shaped rotor blades.

RC Helicopter Components

Kits: Rotor: Coaxial Fixed Pitch

- A special type of fixed pitch model helicopter is a coaxial rotor machine.
- On a coaxial rotor helicopter...
 - two main rotors turn in opposite directions.
 - a tail rotor is not required because...
 - the torques of the two rotors cancel, so the helicopter's body doesn't turn.
 - an intentional torque differential can be created to provide rudder control.
- This type of helicopter tends to be very stable (i.e. easy to hover).



Above: Hirobo Lama XRB helicopter



Above: E-Flite Blade CX helicopter

RC Helicopter Components

Kits: Rotor: Collective vs Fixed (1)



Model Helicopter Insights™
RC Helicopter Primer

- Collective pitch helicopters:
 - More complex rotor head mechanics
 - More moving parts
 - Possibly a little less robust
 - Handles better in windy conditions
 - Capable of inverted flight
 - Internal combustion or electrically powered machines
 - Mostly larger helicopters, although collective pitch micros are available
- Fixed pitch helicopters:
 - Simpler rotor head mechanics
 - Fewer moving parts
 - Possibly simpler assembly
 - Possibly a bit more robust
 - May not handle well in windy conditions
 - Not capable of inverted flight
 - Most often electrically powered machines
 - Typically smaller helicopters
 - Sometimes use coaxial rotor head design

RC Helicopter Components

Kits: Rotor: Collective vs Fixed (2)



Model Helicopter Insights™
RC Helicopter Primer

- A collective pitch helicopter is more responsive than an equivalent fixed pitch machine because of the *rotational inertia* of the rotor disc.
- Rotational inertia is the tendency of a rotating object to resist decreases or increases in the speed of rotation.
- To vary the lift generated by a fixed pitch helicopter, the speed of the rotor disc's rotation must be changed (i.e. decreased for less lift, increased for more lift).
- Because the rotor disc's inertia resists changes in rotor speed, control inputs to vary lift incur time delays that can be quite noticeable.
- With a collective pitch helicopter, the blade angle is changed to vary the lift while the rotor speed remains constant.
- Because the blade angle can be changed relatively rapidly, collective pitch machines respond quickly to commands to change lift.
- As a result, collective pitch helicopters are more responsive and easier to manage in windy (especially gusty) conditions than their fixed pitch counterparts.

RC Helicopter Components

Kit Characteristics: Heli Sizes

- RC helicopters come in a variety of sizes.
 - Approximate minimum rotor diameter: 300mm or 12in
 - Approximate maximum rotor diameter: 1600mm or 63in
- Various (potentially confusing) systems are used to classify RC helicopters by size.
 - The sizing system for internal combustion (IC) powered helicopters is relatively straight forward.
 - For electric power (EP) helicopters, it can get complicated.

RC Helicopter Components

Kit Characteristics: Size, IC

- An internal combustion-powered helicopter is typically classified by the approximate displacement volume of its engine.
 - The following four size classes are most commonly used: 30, 50, 60, 90
 - A 30-size helicopter, for example, would run on a 0.32, 0.37 or maybe 0.40 cu-in displacement engine.
- 30 and 50-size IC helicopters...
 - tend to share a lot of parts.
 - are different primarily in terms of...
 - size of engine mount.
 - gear ratio.
 - size of rotor blades.
 - length of tail boom.
 - power-to-weight ratio, with a 50-size having much more power for its weight.
- The larger machines may employ higher-performance (e.g. metal instead of plastic) parts in some areas.
 - A 30-size IC machine can almost always be upgraded to a 50-size.
 - The same tends to be true for 60 and 90-size IC helicopters.

RC Helicopter Components

Kit Characteristics: Size, EP (1)

- EP helicopter size classification 1: IC helicopter equivalence
 - Because internal combustion-powered helicopters have been around longer, electric helicopters are sometimes labeled with the sizes of equivalent IC helicopters (e.g. 30-size).
 - At this time, the largest electric helicopter is roughly equivalent to a 60-size IC machine with main rotor blades up to 690mm long (approximately 1550mm rotor diameter).
- EP helicopter size classification 2: NiMH cell count
 - The names of some helicopters include a number that is the number of NiMH (or maybe NiCD) cells those helicopters were designed for.
 - Examples: Mikado Logo 10, Century Swift 16
 - The Logo10 and Swift 16 were designed to work with 10-cell and 16-cell NiMH battery packs, respectively.
 - In reality, pilots often use bigger batteries, such as a 12-cell pack for a Logo 10.
 - Helicopters designed for 10 to 16 cells are roughly equivalent to 30-size helicopters. (The Logo 10 is actually designed for 500mm blades while a true 30-size would use 550mm blades.)

RC Helicopter Components

Kit Characteristics: Size, EP (2)

- EP helicopter size classification 3: motor size
 - In another scheme, a number indicates the size of the electric motor, although this system gets very confusing as there is no real standard, and it is not applied consistently.
 - Examples: HeliMax MX400, Align T-Rex 450 SE
 - These machines are designed for 400 or 450-size electric motors.
 - The blade length for these example helicopters is in the neighborhood of 320mm.
- EP helicopter size classification 4: main rotor blade length
 - In some cases, the number in the helicopter name is the length of the main rotor blades (i.e. the length of one blade, not the rotor diameter).
 - Examples: Thunder Tiger Raptor E550, Align T-Rex 600, Century Swift 620
 - The Raptor E550 uses 550mm main blades and is equivalent to a 30-size IC helicopter.
 - The T-Rex 600 and the Swift 620 are intended for 600 and 620mm blades, respectively, and are equivalent to a 50-size IC helicopter.

RC Helicopter Components

Kit Characteristics: Size, EP (3)

- Newer electric helicopters (except for 450-size*) tend to be named using the blade length method; the other systems are falling out of favor.
 - Motor size: The motor sizing approach is not really a standard system and therefore too ambiguous.
 - NiMH cell count: LiPo batteries have displaced NiMH batteries, so NiMH cell count is no longer a very meaningful designation.
 - IC equivalence: IC equivalent sizes can be useful when applied to electric helicopters but are not ideal since electric machines don't really use internal combustion engines.
 - Main rotor blade length, in contrast, is a clear size identifier that also makes perfect sense for IC helicopters.
- RC helicopters are sometimes also described as micro or mini helicopters.
 - Micro and mini helicopters are predominately electric machines.
 - The HeliMax MX400 and T-Rex 450, for example, are typically considered mini helicopters; the T-Rex 500† and Logo 400 may also qualify as minis.
 - Micro helicopters are smaller than minis.

* 450-size machines have approximately 320mm blades, but they seem to be stuck with their awkward, motor size-based name.

† The T-Rex 500 actually uses 430mm blades. As in the 450 case, the “500” is an unfortunate and misleading identifier.

RC Helicopter Components

Kit Characteristics: Size, General (1)





Model Helicopter Insights™
RC Helicopter Primer

- Fixed pitch rotor heads can be found in micro or mini helicopters.
- Collective pitch micros and minis are available and all larger helicopters are exclusively collective pitch machines.
- Larger helicopters are more stable in flight and less affected by wind than smaller ones.
- Larger helicopters also tend to be more expensive.
- Micro helicopters are typically only suited for indoor flight.
- Mini helicopters may be flown outdoors or in large indoor spaces.
- All larger models need to be flown outdoors; IC models need space where engine noise is not an issue.

RC Helicopter Components

Kit Characteristics: Size, General (2)

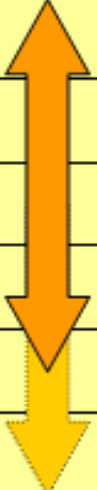
Helicopter Size Summary Table

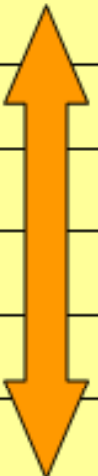
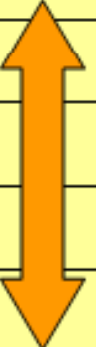
Electric Power	Size Class	Rotor Type		Fuselage Length		Rotor Diameter		Main Rotor Blade Length (approx. mm)	Internal Combustion Power
		Fixed Pitch	Collective Pitch	(approx. mm) (approx. in)	(approx. mm) (approx. in)	(approx. mm) (approx. in)			
	Micro			200 - 500	300 - 550	130 - 250			
	8 - 20			12 - 22					
	Mini	620 - 850		680 - 980	300 - 430				
	24 - 33	27 - 39							
	30	1000 - 1170		1150 - 1250	500 - 550				
	39 - 46	45 - 49							
50	1150 - 1260	1350 - 1400	600 - 620						
45 - 50	53 - 55								
60	1250 - 1400	1400 - 1580	610 - 690						
49 - 55	55 - 62								
90	1330 - 1500	1580 - 1800	690 - 800						
52 - 59	62 - 71								

Electric helicopters for the volume market are currently no larger than 600mm blade machines (i.e. 50-size equivalent). Some larger electric helicopters are available as special kits or custom IC helicopter conversions.

RC Helicopter Components

Kit Characteristics: Tail Drive

- One size-related consideration is how the tail rotor is driven and controlled.
- Two options exist:
 - The tail rotor is driven off the main engine or motor (i.e. the model only has one engine or motor) through a belt or shaft that runs through the tail boom.
 - The tail rotor is driven by a separate, dedicated motor.
- Separate tail motors are typically only found on micro-sized electric helicopters.
- On a micro with a separate tail motor...
 - the tail rotor uses fixed-pitch blades, and thrust is varied by varying the speed of the tail rotor.
 - an electronic speed controller takes the place of the rudder pitch control servo.

RC Helicopter Components

Kits: Tail Drive: Separate Motor



Above and to the right: Ikarus Piccolo helicopter



Above: Century Hummingbird helicopter



Electric micro-helicopters tend to use separate motors to drive their tail rotors.

The tail blades are fixed-pitch blades and tail rotor thrust is varied by varying rotor speed.

RC Helicopter Components

Kits: Tail Drive: Shaft or Belt Drive

Larger electric helicopters as well as internal combustion-powered helicopters use tail rotors that are driven off the main motor or engine by a shaft or belt. These tail rotors are variable-pitch rotors.



Above: Align T-Rex 600 Nitro Pro 50-size IC helicopter with torque tube drive for the tail (close up photo by W. Witt)

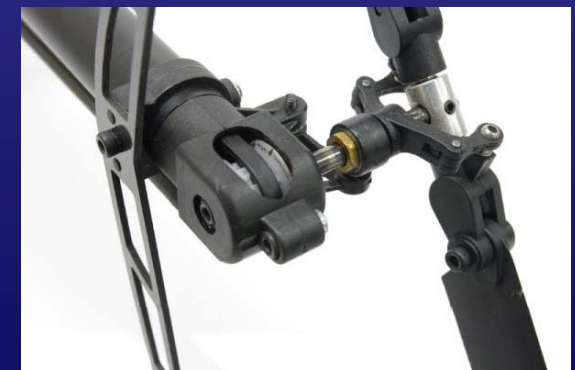

Above: Century Swift electric helicopter (30-size equivalent) with a belt-driven tail



Above: Align T-Rex 450 SE electric mini helicopter with a belt-driven tail



RC Helicopter Components

Kits: Tail Drive: Tradeoffs



Model Helicopter Insights™
RC Helicopter Primer

- The separate tail motors on micro helicopters...
 - will not provide very crisp tail (rudder) control (which is ok for learning basic skills but may be a limitation later).
 - tend to be brushed motors.
 - may wear out frequently.
- Some people choose to upgrade their tail motors to more expensive brushless motors for increased...
 - reliability.
 - responsiveness.
- Belt or shaft-driven, variable-pitch tail rotors...
 - increase the mechanical complexity of the tail drive.
 - can provide very crisp rudder control.
- Belt drives...
 - are less expensive than drive shafts.
 - are more likely to survive crashes.
 - are sometimes sources of electrical noise due to electro-static discharge (similar to Van de Graaff generators).
- Shaft or *torque tube* drives...
 - are more expensive and more likely to be damaged during crashes.
 - provide crisper tail response during aggressive aerobatic maneuvers.
 - are more efficient (i.e. impose less drag) during auto-rotation maneuvers.

RC Helicopter Components

Kit Characteristics: Pitch Mixing

- For collective pitch helicopters...
 - the rotor head mechanism combines collective and cyclic pitch controls (e.g. right cyclic pitch can occur with high or low collective pitch).
 - the swash plate transfers control inputs from the non-rotating part of the helicopter to the rotating part of the rotor head.
- The swash plate has three degrees of freedom:
 - Move up or down (collective pitch)
 - Tilt right or left (right/left cyclic or aileron)
 - Tilt forward or backward (fore/aft cyclic or elevator)
- Two methods exist for controlling the swash plate motion through servomotors.
 - *Mechanical collective/cyclic pitch mixing* (sometimes labeled *mCCPM*)
 - *Electronic collective/cyclic pitch mixing* (*eCCPM* or sometimes just *CCPM*)

RC Helicopter Components

Kits: Pitch Mixing: mCCPM (1)

- Mechanical pitch mixing dedicates one servo to each of the swash plate's degrees of freedom.
 - One servo is responsible for moving the swash plate up or down.
 - A second servo can tilt the swash plate right or left.
 - A third servo can tilt the swash plate forward or backward.
 - The individual servo movements are then combined (or mixed) through a mechanical system of levers and bell cranks.

Bell Crank: A crank with two arms arranged in an L shape and hinged where the arms meet.



RC Helicopter Components

Kits: Pitch Mixing: mCCPM (2)

Mechanical Collective/Pitch Mixing (mCCPM):

Each swash plate control (collective pitch, right/left cyclic pitch, fore/aft cyclic pitch) is controlled by a servo dedicated to that control.

Combinations of these controls are mechanically mixed.

Collective Pitch Servo

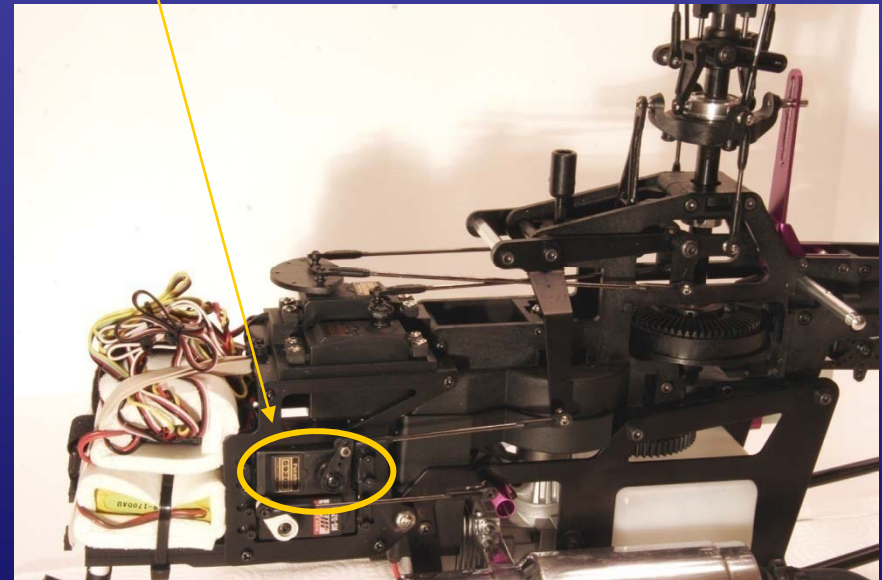

Above: Century Hawk Pro helicopter (Photo by W. Witt)

RC Helicopter Components

Kits: Pitch Mixing: mCCPM (3)

Right/Left Cyclic Pitch Servo (Aileron)

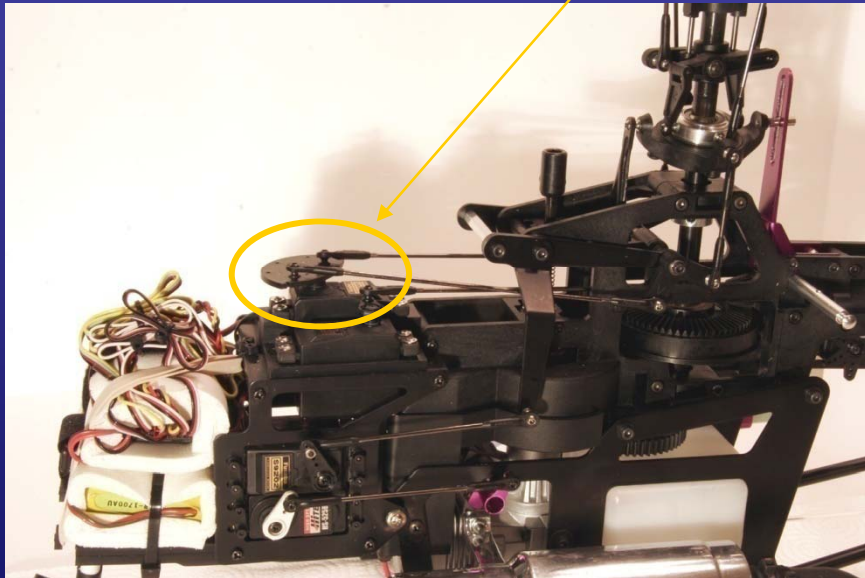

Fore/Aft Cyclic Pitch Servo (Elevator)

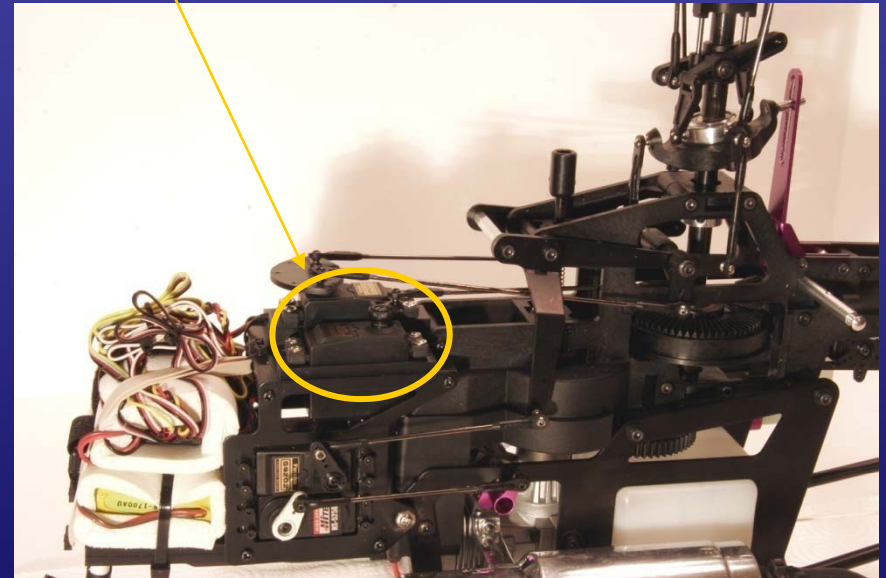

Above and left: Century Hawk Pro helicopter (Photos by W. Witt)

RC Helicopter Components

Kits: Pitch Mixing: eCCPM (1)

- With electronic pitch mixing...
 - each of the three servos controls one point on the swash plate, with the control points typically 120° (or sometimes 90° , 135° or 140°) apart.
 - the servos always work together to move the swash plate to the desired position.
 - To increase collective pitch, all three servos will push the swash plate up.
 - To tilt the swash plate, some servos will push one side of the swash plate up, while other servos pull the other side of the swash plate down.
- Electronic pitch mixing...
 - allows for simpler pitch control mechanics.
 - requires that the radio control transmitter can...
 - perform the function of electronically mixing collective and cyclic pitch commands.
 - coordinate the motion of the swash plate servos.

RC Helicopter Components

Kits: Pitch Mixing: eCCPM (2)



Above: Century Raven 50 helicopter

- The picture on the left shows an example of an eCCPM helicopter.
- Two of the three swash plate servos are clearly visible.
- The third servo is obscured by the model's airframe.
- Each servo connects to one point on the swash plate through one push rod.

RC Helicopter Components

Kits: Pitch Mixing: eCCPM (3)



Model Helicopter Insights™
RC Helicopter Primer

Electronic Collective/Cyclic Pitch Mixing (eCCPM):

Three servos control the swash plate together, with each servo connecting to the swash plate at one specific point. In this example, these points are 120° apart. (90°, 135° and 140° eCCPM configurations also exist.)

To move the swash plate for a collective or cyclic pitch change, two or three servos need to move, and the mixing required to achieve the correct motion occurs electronically in the transmitter.

Collective Pitch Control

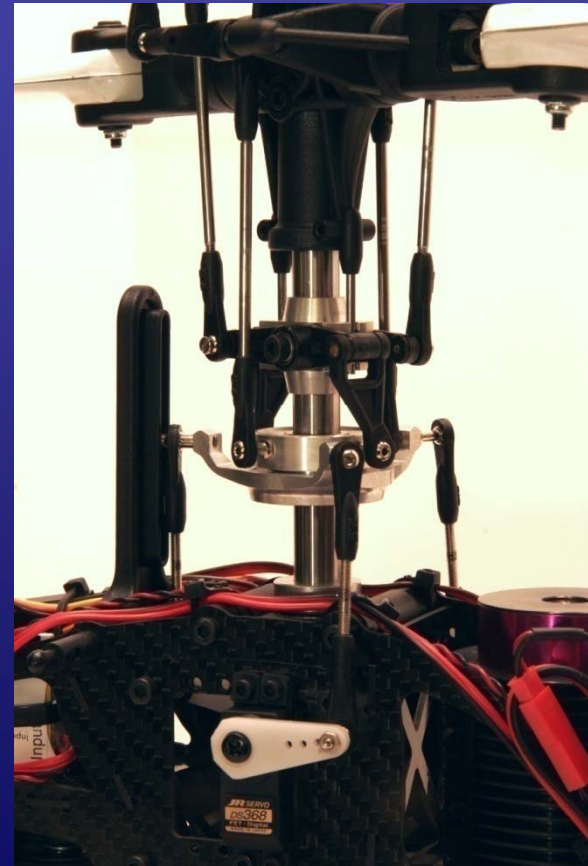

Above and left: Mikado Logo 10 Carbon helicopter
(Photo by W. Witt)

RC Helicopter Components

Kits: Pitch Mixing: eCCPM (4)



Model Helicopter Insights™
RC Helicopter Primer

Right/Left Cyclic Pitch Control (Aileron)

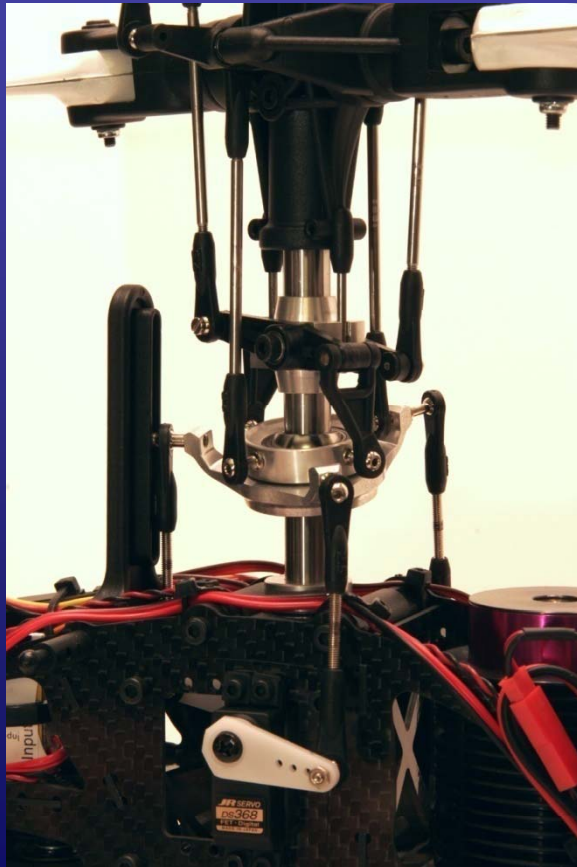

Fore/Aft Cyclic Pitch Control (Elevator)

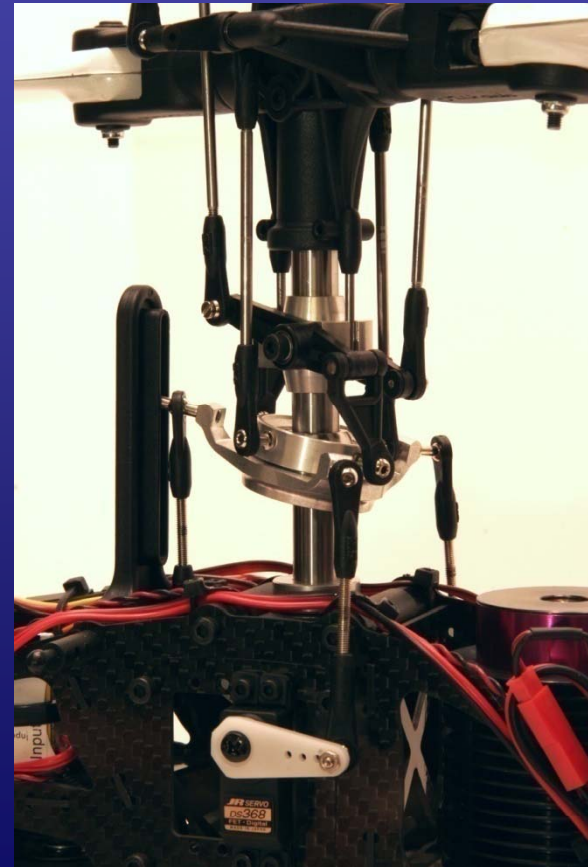

Above and left: Mikado Logo 10 Carbon helicopter
(Photos by W. Witt)

RC Helicopter Components

Kits: Pitch Mixing: eCCPM (5)

120° Swash Plate
(Abstraction)

120° Swash Plate
(Gaiu Hurricane 550 Helicopter)

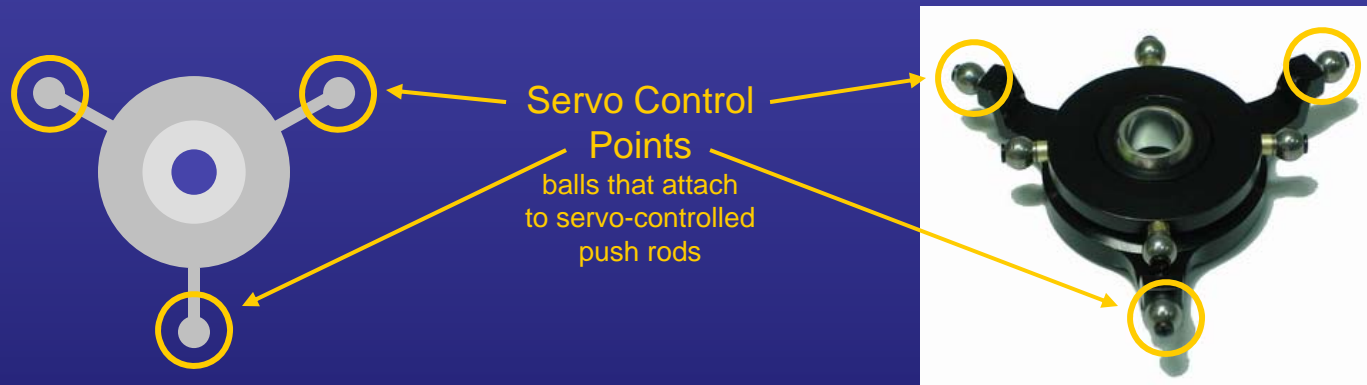

- The following two slides illustrate the different eCCPM swash plate types.
- For this purpose, the swash plates are represented by abstract drawings that...
 - show only the balls that attach to servo-controlled push rods.
 - do not show the top part of the swash plate, the part that connects to the rest of the rotor head mechanism (e.g. the blade grips).

RC Helicopter Components

Kits: Pitch Mixing: eCCPM (6)

120° Swash Plate

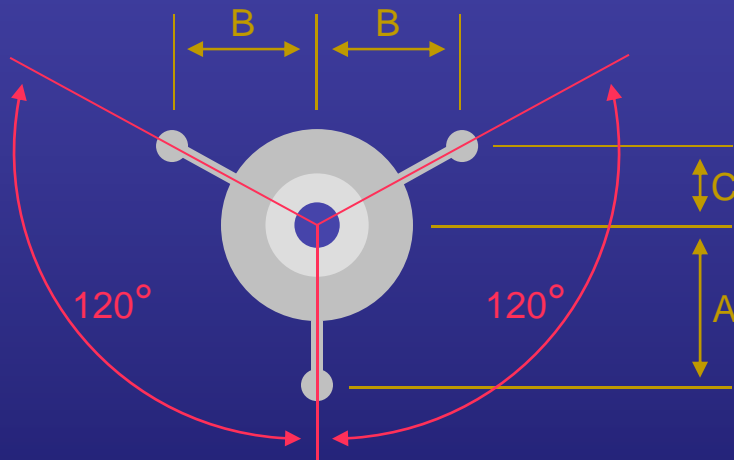

90° Swash Plate

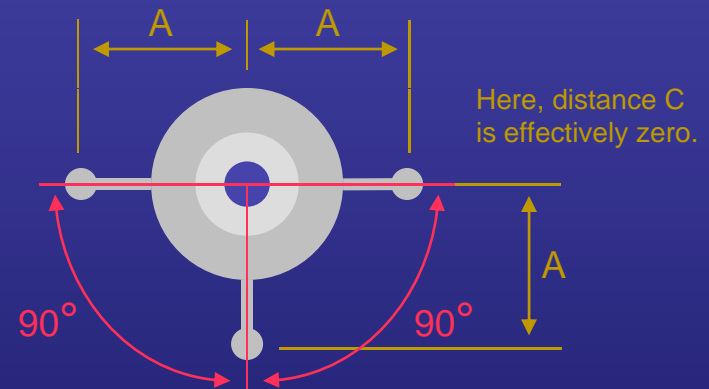

- A, B and C denote the different linear distances from a swash plate's center to the control points where servo-controlled push rods attach.
- Most eCCPM helicopters employ 120° swash plates.
- 90° swash plates are rarely used.

RC Helicopter Components

Kits: Pitch Mixing: eCCPM (7)

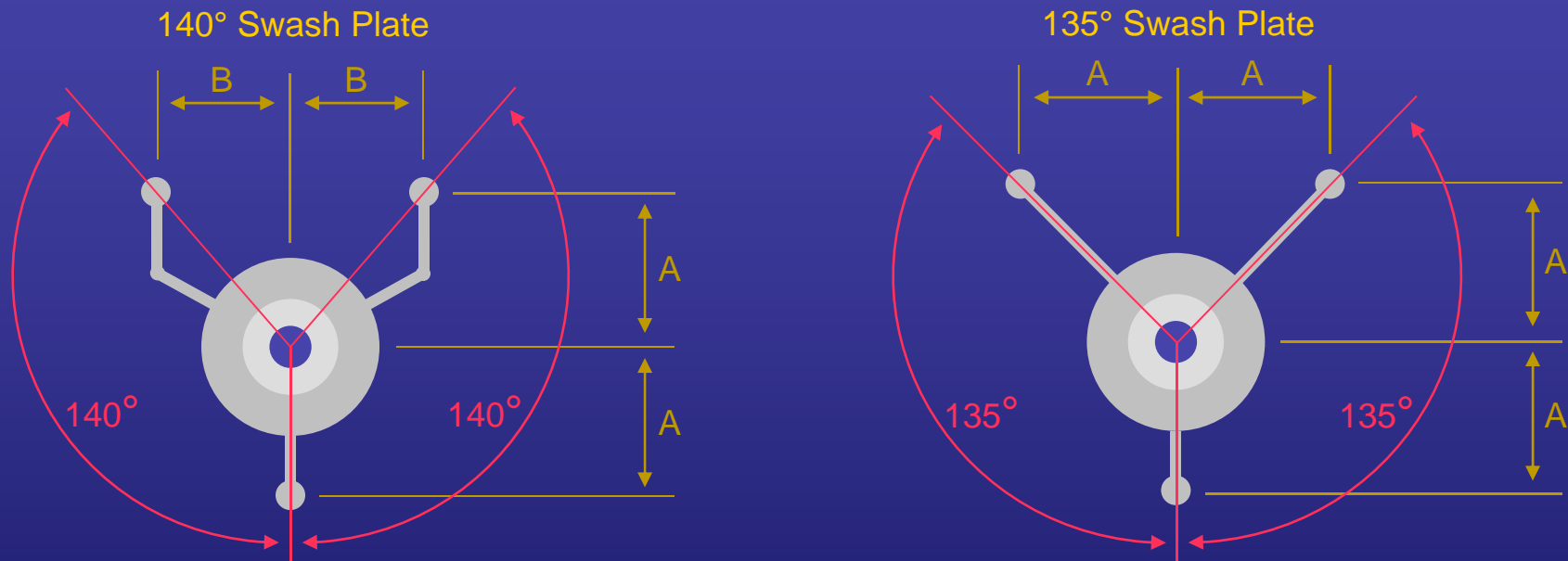

- A 140° swash plate is a derivative of the 120° version.
 - The 140° swash plate is an improvement in that the two distances in the fore/aft direction are now the same (i.e. both A).
 - In the 120° case, these two distances were different (i.e. A and C).
- With a 135° swash plate, all of the important linear distances are the same.

RC Helicopter Components

Kits: Pitch Mixing: m vs eCCPM (1)



Model Helicopter Insights™
RC Helicopter Primer

- Computerized radios that can perform complex signal mixing operations made eCCPM RC helicopters possible.
- Most new RC helicopter designs employ eCCPM because compared to mCCPM, eCCPM results in simpler control mechanics.
- Simpler control mechanics translate to helicopters that...
 - consist of less parts.
 - have lower production costs.
 - are simpler to assemble (and repair in case of a crash).
 - weigh less (and may therefore be a bit more agile in the air).

RC Helicopter Components

Kits: Pitch Mixing: m vs eCCPM (2)



Model Helicopter Insights™
RC Helicopter Primer

- Various additional tradeoffs exist between mCCPM and eCCPM systems.*
 - Control response speed
 - Control play
 - Control resolution
 - Control interactions
- Relative to mCCPM, eCCPM may improve control response speeds, especially for the collective pitch control.
 - At least two servos participate in every swash plate position change; collective pitch changes always involve all three servos.
 - Because multiple servos share the control load, torque requirements per servo are lower, such that faster servos may be used (i.e. servo torque can be traded for servo speed).
 - Actual benefits (if any) depend on servo choice and setup.

* As a beginner, you may not care about these tradeoffs, and they may not make sense yet. Nevertheless, they are presented here for completeness because mCCPM versus eCCPM discussions among model pilots often turn into heated debates.

RC Helicopter Components

Kits: Pitch Mixing: m vs eCCPM (3)



Model Helicopter Insights™
RC Helicopter Primer

- eCCPM tends to have less rotor head control play or slop.
 - In eCCPM systems, servos are connected to the swash plate more directly; mCCPM systems tend to use more linkages and bell cranks.
 - Every link and bell crank is an opportunity for additional mechanical play, so less links and bell cranks mean less play.
- With eCCPM the resolution of each control is reduced.
 - The exact position of a servo within its range of motion may be controlled with a certain accuracy or resolution, say 1024 steps.*
 - With mCCPM, a servo's full range of motion is dedicated to only one control.
 - With eCCPM, each servo's range, and so the resolution, is split between collective and cyclic pitch.
 - In practice, this difference in effective resolution tends to be imperceptible.

* The position control signal into a servo is analog in nature, but with today's digital systems, quantization is bound to happen somewhere between the transmitter sticks and the servo output.

RC Helicopter Components

Kits: Pitch Mixing: m vs eCCPM (4)



Model Helicopter Insights™
RC Helicopter Primer

- Control interactions are undesirable and occur when collective pitch changes introduce unwanted cyclic pitch changes or vice versa.
- Two types of interaction exist:
 - Static interaction:
 - Once the swash plate has moved to a commanded position, the final position has acquired and maintains an unwanted component.
 - With the Century Hawk Pro helicopter, for example, left or right cyclic pitch while at full negative collective pitch also introduces a small amount of unwanted fore/aft cyclic pitch.
 - Dynamic interaction:
 - While the swash plate is moving, the motion is not pure, that is an unwanted component is temporarily present.
 - For an eCCPM helicopter with a 120° swash plate, for example, ...
 - rapid fore/aft cyclic motion tends to cause the swash plate to bob up and down.
 - while the swash plate is moving to a newly commanded cyclic pitch position, a small, unwanted collective pitch change creeps in temporarily.

RC Helicopter Components

Kits: Pitch Mixing: m vs eCCPM (5)



Model Helicopter Insights™
RC Helicopter Primer

- An mCCPM system...
 - should be virtually free of control interactions (if it is well designed).
 - is most likely affected by interactions (if any) near or at the positive and negative extremes of the collective pitch range.
- An eCCPM system...
 - is more susceptible to control interactions.
 - must be built with three identical, well-matched servos for swash plate control.
 - requires more care, as interactions due to setup errors are more likely to occur.
- Sources of control interactions in eCCPM systems are:
 - nonlinearities because servos arms move in arcs, while a swash plate's control points move in more of a straight-line fashion (usually affects fore/aft cyclic vs. collective control the most)
 - asymmetries in swash plate or control linkage geometries
 - imbalanced computation or transmission delays among the three swash plate control channels (severity depends on make and model of radio gear)
 - servo performance mismatches (rare for servos of identical make, model and age)

RC Helicopter Components

Kits: Pitch Mixing: m vs eCCPM (6)



Model Helicopter Insights™
RC Helicopter Primer

- Especially with advanced computer transmitters, unwanted control interactions can often be eliminated or at least greatly minimized through mixing programs.
 - For eCCPM...
 - static interactions can usually be avoided through careful mechanical, servo and radio setup.
 - dynamic interactions can be difficult to eliminate, but some advanced transmitters offer special mixing functions for this purpose.
 - For mCCPM...
 - interactions are unlikely but if they do exist, they tend to be of the static variety.
 - can usually be eliminated through custom mixing programs.
 - Mixing programs to remove interactions...
 - may be beyond the abilities of RC helicopter novices.
 - are typically not necessary for basic flight (assuming the basic mechanical setup is good).
- mCCPM and eCCPM are both perfectly fine systems.
 - High-performance helicopters of either type exist.
 - mCCPM systems may be a bit easier to understand and set up for individuals who are new to RC helicopters.
 - Assuming a good mechanical setup, minor dynamic eCCPM control interactions are not likely to cause problems for beginning or even intermediate pilots.

RC Helicopter Components

Servo Flashback: eCCPM Servos



Model Helicopter Insights™
RC Helicopter Primer

- The servo guidelines presented earlier were in the context of an mCCPM system.
- In an eCCPM system, there is no concept of separate cyclic and collective pitch servos.
- With eCCPM, three servos work together for collective and cyclic pitch control.
- In terms of relative torque and speed, those eCCPM servos are roughly equivalent to the cyclic pitch servos of the mCCPM system.
- The tail pitch and throttle functions are not affected whether the rotor head is implemented with mCCPM or eCCPM.

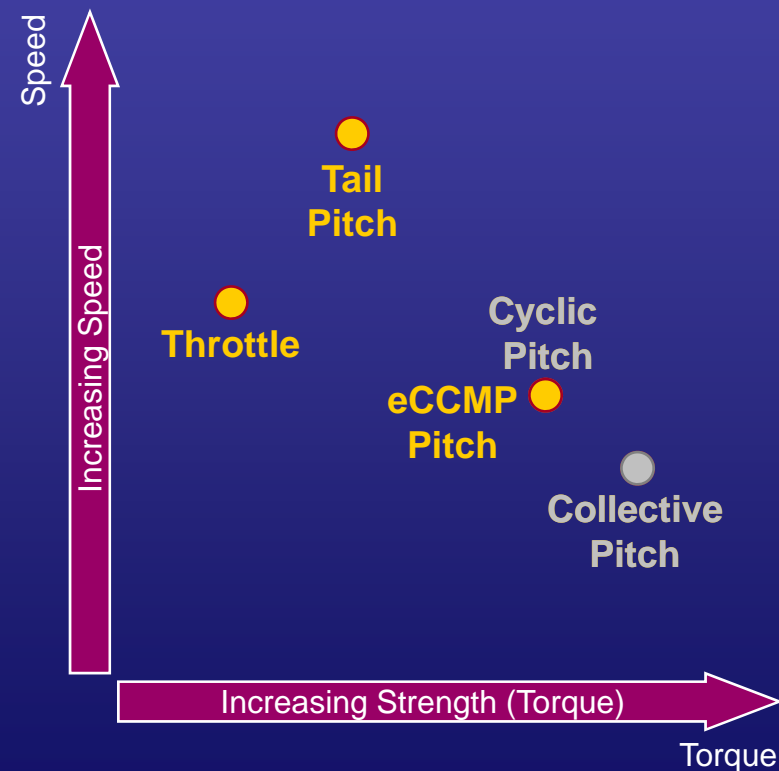

RC Helicopter Components

Kit Characteristics: Performance Parts (1)



Model Helicopter Insights™
RC Helicopter Primer

- Entry-level helicopters tend to...
 - consist of a lot of plastic parts.
 - use main rotor blades made of wood (or foam or plastic for some micro helicopters).
- More expensive (and presumably more capable) machines will...
 - include more glass fiber, carbon fiber and/or metal parts.
 - use main rotor blades made of fiberglass or carbon fiber.
- Plastic parts tend to...
 - flex more under mechanical stress (e.g. during extreme aerobatic maneuvers).
 - wear out faster and develop more slop over time.
- Fiberglass, carbon and metal parts...
 - are stronger and more rigid.
 - are relatively slop free and much more durable.
 - cost significantly more (about five to ten times more) than their plastic equivalents.

RC Helicopter Components

Kit Characteristics: Performance Parts (2)



Model Helicopter Insights™
RC Helicopter Primer

- Most helicopters fly just fine with plastic parts.
 - New pilots will not feel a difference between plastic and carbon or metal for some time.
 - Plastic parts are much cheaper to replace after a crash.
 - Even if a plastic part wears out, it can usually be replaced several times for the cost of the metal version.
- Metal parts are not automatically good-quality parts.
 - Metal parts that are die cast sometimes do not work well.
 - High-quality parts tend to be computer numerical control (CNC) machined.
- Some plastic parts are very good.
 - Some helicopters are made with high-quality plastic parts (e.g. plastic airframes).*
 - Some high-grade plastics are comparable to carbon fiber in strength and rigidity.

* Some helicopters (e.g. Mikado Logo 600), for example, have airframes that are made from glass fiber-reinforced plastic.

RC Helicopter Components

Kit Characteristics: Performance Parts (3)



Model Helicopter Insights™
RC Helicopter Primer

- Then again...
 - metal parts (e.g. blade grips) may survive crashes better than plastic parts.
 - carbon fiber and metal parts definitely look cool. 😊
- Some pilots...
 - consider the appearance of their helicopters to be at least as important as how well they fly.
 - spend a lot of money on fancy, shiny parts (a.k.a. bling) that don't necessarily improve flight characteristics.
- Almost all helicopters can be upgraded over time with additional metal or carbon parts.

RC Helicopter Components

Kits: Performance Parts: Main Blades (1)



Model Helicopter Insights™
RC Helicopter Primer

- Wood blades...
 - flex (or cone*) more.
 - are less power efficient.
 - cannot withstand very high rotor speeds.
- Carbon blades...
 - are more rigid and more power efficient, thereby...
 - making a helicopter's controls more responsive.
 - enabling high-power/high-stress maneuvers.
 - may be run at very high rotor speeds, thereby again increasing the responsiveness of the helicopter.
 - cost much more (about three to six times more) than wood blades.
- Wood blades are perfectly fine for new pilots learning hovering, forward flight and even basic aerobatics (e.g. loops and rolls).
- Fiberglass or carbon blades are only required for advanced aerobatic maneuvers.

* Coning occurs when the rotor blades flex up (or down) under load, such that the spinning rotor appears like a shallow cone rather than a flat disc.

RC Helicopter Components

Kits: Performance Parts: Main Blades (2)



Model Helicopter Insights™
RC Helicopter Primer

- Kits for entry-level helicopters (e.g. micros, minis, 30-size) typically include a basic set of main rotor blades.
- Kits for intermediate and high-end helicopters often do not include any main rotor blades; blades may need to be purchased separately.

RC Helicopter Components

Kits: Performance Parts: Example



Two versions of the T-Rex 450 helicopter from Align: the top has a plastic frame, plastic rotor head components and plastic main blades, while the bottom has a carbon fiber frame (here silver but usually black in color), metal rotor head components and carbon main blades.

RC Helicopter Components

Kits: Performance Parts: Bearings



Model Helicopter Insights™
RC Helicopter Primer

- Another performance difference comes from whether a helicopter uses simple bushings or ball bearings.
- A rotor head mechanism relies on many hinges and other rotating parts.
 - Pivoting and rotating parts that are mounted through ball bearings result in tight fits while still allowing smooth rotation.
 - Bushing mounts result in looser fits that translate to slop in the rotor head control mechanism.
- While a helicopter with lots of bushings is fine for initial practice and basic forward flight, a helicopter with a full set of bearings is probably worth the additional cost.
- If a helicopter uses some bushing mounts, ball bearing upgrades are usually available.

RC Helicopter Components

Kit Characteristics: Build Types (1)

- Model helicopters come in four basic states of completeness:
- Ready to Fly (RTF):
 - The model is fully assembled with motor and avionics installed.
 - A basic radio control transmitter and batteries (and charger if needed) are often included.
 - The model should be ready to fly after taking it out of the box and installing and charging the batteries (and reading the instructions).
 - Even RTF models sometimes benefit from minor adjustments to tune their flight behavior.
- Almost Ready to Fly (ARF):
 - Excluding the motor and avionics which may not be included in the package...
 - the kit may come fully assembled.
 - only major sub-components (e.g. the rotor head) may be pre-assembled.
 - A transmitter and batteries are most likely not included.
 - An ARF model will be ready to fly after...
 - final assembly of the basic kit (if necessary).
 - installation of the motor or engine, as well as the avionics.
 - set up of the model's mechanics (e.g. rotor head and tail control linkages).
 - set up of the radio control transmitter.

RC Helicopter Components

Kit Characteristics: Build Types (2)

- Model helicopters come in four basic states of completeness (cont):
- Kit:
 - The model's frame, rotor head, and other sub-components come as a collection of small pieces (individual plastic, glass fiber, carbon fiber or metal parts; screws; nuts; bearings) that need to be assembled.
 - A motor, avionics and a transmitter are typically not included and need to be purchased separately.
 - A model built from a kit is ready to fly after...
 - assembly of the kit.
 - installation of the motor or engine as well as the avionics.
 - set up of the model's mechanics (e.g. rotor head and tail control linkages).
 - set up of the radio control transmitter.
- Custom Built:
 - The model is fully assembled including motor and avionics.
 - The components in the model are from a package offered by a particular hobby shop.
 - The assembly and set up (and ideally a test flight) were done by someone at that hobby shop.

RC Helicopter Components

Kit Characteristics: Build Types (3)

- RTF helicopter models are usually small electric machines.
- ARF helicopter models may be small electric or 30-size machines at the entry level.
- Intermediate or advanced helicopter models almost always come in kit form.
- A custom-built helicopter could be anything, including a helicopter that would otherwise be available only as a kit.
- Virtually all intermediate or advanced RC helicopter pilots do not trust machines built by others; they...
 - build their own from kits, or...
 - first disassemble and then reassemble factory-assembled components.

RC Helicopter Components

Kit Characteristics: Manuals

- The instruction or assembly manuals that come with RC helicopters...
 - vary in their levels of completeness and quality, sometimes...
 - ☺ providing well organized, clearly written instructions with helpful pictures and diagrams.
 - ☹ leaving out important steps or showing pictures that are wrong.
 - even in the best case, rarely provide all of the information required to fully assembly and tune a model helicopter.
- Individuals who are new to building RC helicopters often need to draw on other sources of information:
 - additional books
 - discussion boards on the internet
 - experienced modelers and pilots
- The next few slides show some examples of helicopters and their manuals.

RC Helicopter Components Kit and Manual Example (5)

Align T-Rex 600 Nitro Pro Kit Glow Fuel Helicopter

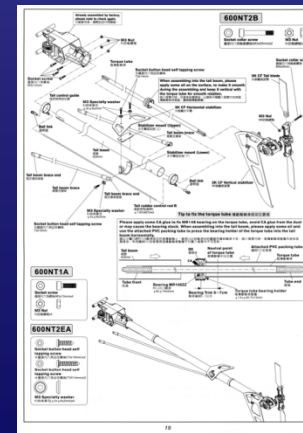
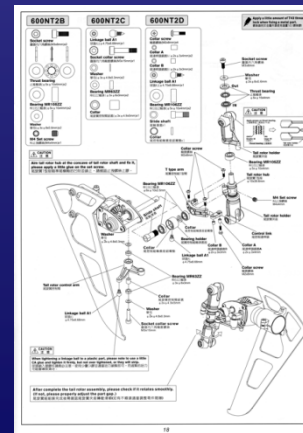
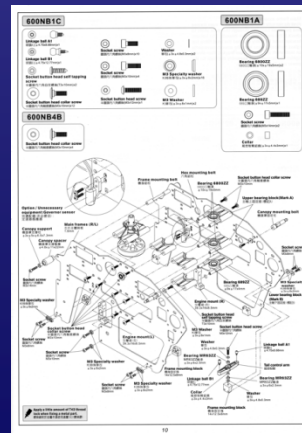
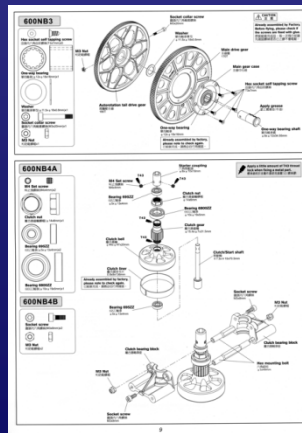
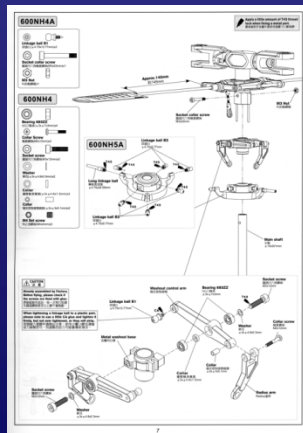
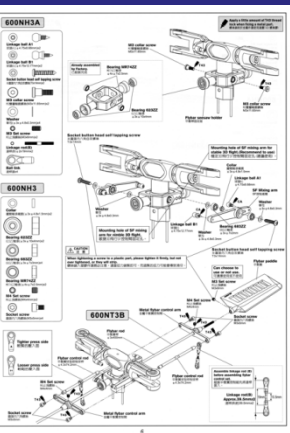
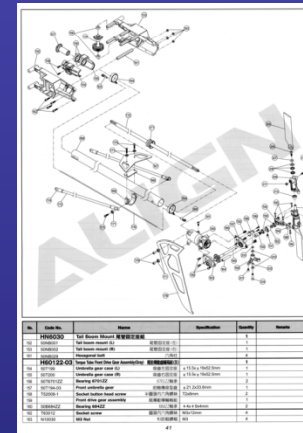
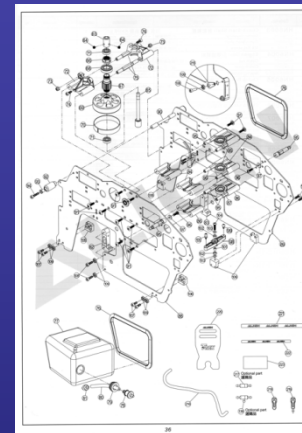

RC Helicopter Components Kit and Manual Example (7)



Model Helicopter Insights™
RC Helicopter Primer

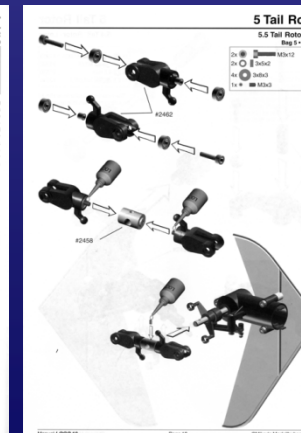
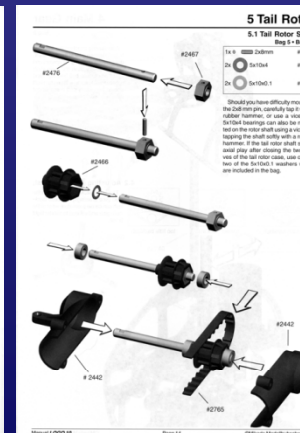
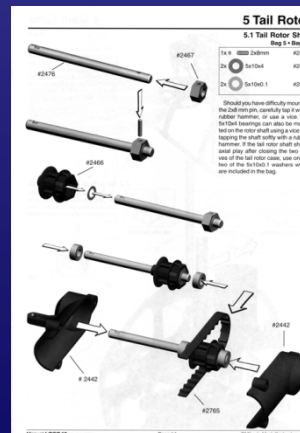
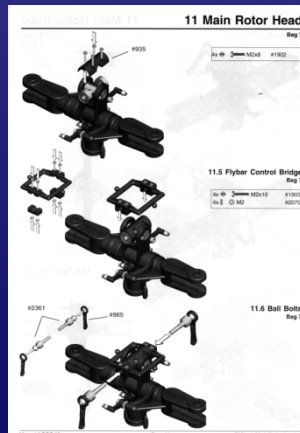
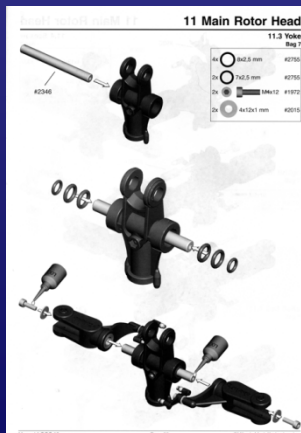
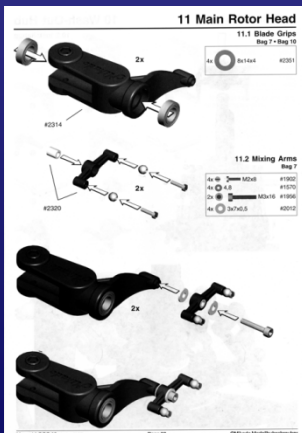
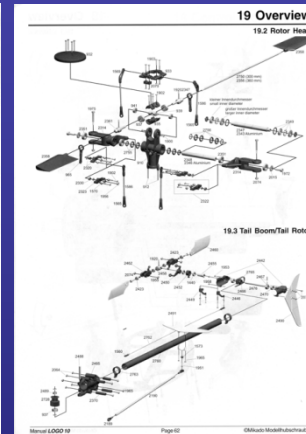
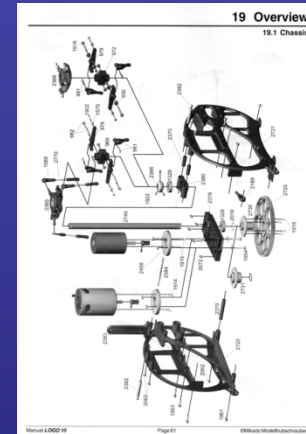
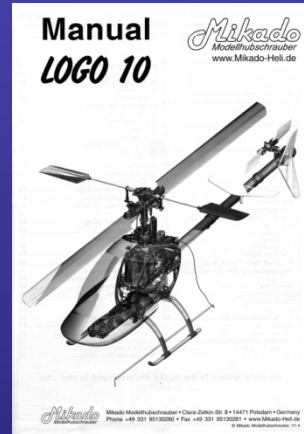

RC Helicopter Components

Kit Characteristics: Spare Parts

- Two other, less obvious but important differences among helicopters are the...
 - availability of spare parts.
 - cost of spare parts.
- Parts for a particular helicopter may or may not be available at the local hobby shop.
- While almost all parts are available somewhere on the internet, shipping time and postage may be a factor.



Above: Thunder Tiger Raptor 30 helicopter with canopy (top), without canopy (left), and assorted parts (above)



RC Helicopter Primer

RC Helicopter Component Details

Power Systems

Servos

Helicopter Kits

Gyros

Governors

Automatic Mixture Controllers

Transmitters and Receivers

BECs / Voltage Regulators

Multi-Function Modules

Tools and Equipment

RC Helicopter Components

Gyros: Purpose



Model Helicopter Insights™
RC Helicopter Primer

- Recall from *Basic Principles of Operation* that...
 - the body of a helicopter tends to spin in the direction opposite the main rotor spin.
 - the tail rotor provides thrust to compensate for this tendency.
- The strength of the tendency to spin depends on the torque generated by the engine.
- During hover or flight, the pilot needs to vary engine power continuously, so the balancing tail rotor thrust needs to vary, too.
- Keeping the tail steady requires very fast reactions and is very challenging to do by hand.
- RC helicopter pioneers used to fly this way, but today everybody flies with a *gyro*.



Above: Impala helicopter model from RealFlight G3 simulator

RC Helicopter Components

Gyros: Operation



Model Helicopter Insights™
RC Helicopter Primer

- A device called a *gyroscope* or *gyro* helps keep a helicopter's tail stable.
 - A gyro senses and corrects for unwanted tail movements (around the yaw axis).
 - Unwanted tail movements are any movements not initiated by the rudder control on the transmitter.
- The first helicopter gyros were mechanical devices with spinning wheels.
- Today's gyros...
 - are sophisticated electronic, solid-state devices (e.g. silicon micro-machines).
 - can be very effective at holding a helicopter's tail steady.



Above: Century PG2000 (top left), CSM HLG 200 (top right), Futaba GY401 (middle left), JR G410T (middle right), LogicTech LTG-2100T (bottom)

RC Helicopter Components

Gyros: Application

- Without a gyro, only the pilot's rudder inputs control the tail pitch servo.
- A gyro connects between the pilot's rudder control and the tail pitch servo.
 - When the gyro senses unwanted rotation (yaw), it sends control signals to the servo to stabilize the tail.
 - When the pilot applies a rudder control input, it will pass through the gyro.

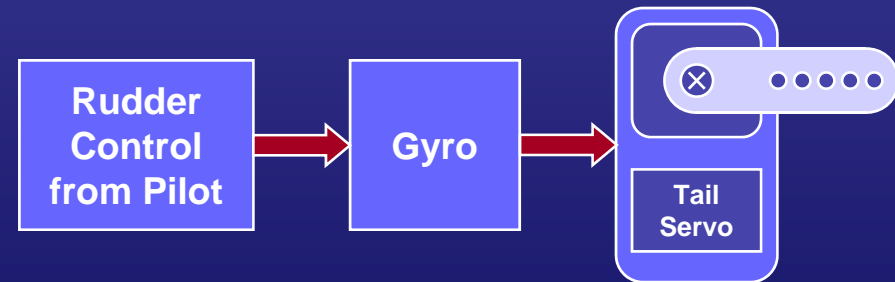

RC Helicopter Components

Gyros: Rate and Heading Hold

- Two types of electronic, solid-state gyros exist:
 - *Rate gyro*
 - *Heading hold gyro*
- A rate gyro...
 - is blind in that it never knows how the helicopter is positioned.
 - will sense unwanted rotation and apply a control input to the tail in an attempt to compensate.
 - cannot measure how successful its compensation is, so its correction may fall short.
- A heading hold gyro...
 - actively tracks the heading of the helicopter at all times.
 - will apply exactly the right amount of compensation to hold or return the helicopter to its original course.
 - tends to be more expensive but is usually worth the extra cost.
- At this time, almost all RC helicopters are set up with gyros in heading-hold mode.
- Scale helicopter models sometimes use rate gyros to achieve flight behavior that more closely mimics that of a full-size helicopter.

RC Helicopter Components

Gyros: Modes and Servos

- “Heading hold” also goes by other names, such as “heading lock,” “tail lock” or “angular vector control system” (AVCS).*
- Some gyros may be switched between rate and heading hold modes.
- Some gyros are available in packages with matched, high-speed (≈ 0.05 sec/ 60°), digital servos that are especially designed for tail control.



Futaba GY401 gyro with S9254 servo (top), JR G3703D gyro with DS3500G servo (bottom)

* AVCS is a Futaba term.

RC Helicopter Components

Gyros: Differences



Model Helicopter Insights™
RC Helicopter Primer

- Low-end gyros may not perform well (i.e. may not hold the tail well) and may make flights, especially learning flights, very frustrating.
- Mid-range gyros typically perform very well for entry-level as well as intermediate helicopters.
- High-end gyros...
 - offer...
 - tighter, steadier tail control during abrupt maneuvers.
 - crisper starts and stops for changes in yaw (i.e. rotations around the helicopter's main rotor axis).
 - more consistent pirouette rates (i.e. speeds of spinning around the main rotor axis).
 - more programming and setup options.
 - upgradeable firmware (in some cases).
 - do not make a noticeable difference for basic and intermediate flight.
 - are beneficial to those who fly aggressive, high-power aerobatic maneuvers.



Above: Futaba GY401, a very popular mid-range gyro (heading hold or rate mode)



Above: high-end gyros: Futaba GY520 (top left), Spartan ds760 (top right), JR G7703D (bottom left), Curtis Youngblood Solid G (bottom right)



RC Helicopter Primer

RC Helicopter Component Details

Power Systems

Servos

Helicopter Kits

Gyros

Governors

Automatic Mixture Controllers

Transmitters and Receivers

BECs / Voltage Regulators

Multi-Function Modules

Tools and Equipment

RC Helicopter Components

Governors: Purpose

- A device that is optional on an RC helicopter is a *speed governor*.
- Recall that on a collective pitch helicopter...
 - rotor speed (i.e. RPM) should be constant.
 - lift should be varied only by varying the blade angle.
- A governor...
 - continuously measures the engine or motor speed.
 - automatically controls the throttle to maintain the speed at a preset value.
- Without a governor...
 - the proper pitch and throttle relationships need to be programmed into the radio control transmitter to (try to) hold the rotor speed constant.
 - a constant speed may be difficult to maintain especially during extreme aerobatic maneuvers.
 - Drops in rotor speed result in losses of power.
 - Overshoots in rotor speed increase the chance of mechanical failure.

RC Helicopter Components

Governors: Availability and Need

- Electronic speed controllers (ESCs) for electric helicopters often include governor features.
- For an internal combustion powered helicopter, a speed governor is a separate device.
 - A governor can hide some symptoms of poor engine tuning, potentially leading to premature engine failure.
 - Flights to tune the engine of an IC-powered helicopter should always be done with the governor off.
- An entry-level and even an intermediate helicopter can fly perfectly fine without a governor (although setting the throttle curves in the transmitter may need to be done by someone with experience).



Above: Speed governors for IC helicopters: Futaba GV1 governor (top, shown here without associated sensor), Model Avionics Throttle Jockey Pro governor (bottom, with sensor and accessories)

RC Helicopter Components

Governors: RPM Limiters (1)

- A special type of governor is an *RPM limiter* or *rev limiter*.
 - RPM limiters are most often used with IC-powered helicopters.
 - An RPM limiter...
 - may have an advantage over a normal governor (especially for aggressive aerobatic flight).
 - is more complicated to set up than a governor.
- With a normal governor, a helicopter may experience a temporary, small reduction in power during a high-power maneuver.
 - Recall that a governor measures the engine speed and adjusts the throttle as needed to maintain a target speed.
 - Assume that a pilot abruptly applies a lot of positive pitch (during upright flight).
 - The load on the engine will quickly increase.
 - The increased load will cause the engine (and rotor) to slow down.
 - The governor will sense the decrease in RPM.
 - The governor will open the engine's throttle further.
 - The engine will speed up until it has returned to the target speed.
 - The governor has some response delay (control loop delay), such that the rotor speed can momentarily drop below the target speed, thereby sapping a little bit of power.

RC Helicopter Components

Governors: RPM Limiters (2)



Model Helicopter Insights™
RC Helicopter Primer

- With an RPM limiter, this response delay can be reduced or eliminated.
 - An RPM limiter is only intended to check and control that the engine (and rotor) do not exceed a maximum speed.
 - The limiter does nothing to open the throttle of the engine if its speed drops below the limit speed.
 - The throttle control signal from the radio transmitter is responsible for keeping the throttle sufficiently wide open.
 - If the transmitter is programmed properly, the throttle signal will track the collective signal, such that increases in throttle happen simultaneously with increases in collective pitch.
 - Control loop delay exists only for the over-speed limiting function (i.e. reductions in throttle).
- Most pilots use governors instead of RPM limiters.
- Some governor devices can be configured to function either way, as full governors or as RPM limiters.



Above: Model Avionics Throttle Jockey RevMax RPM limiter (top, shown with sensor and accessories), Aerospire MultiGov Pro configurable as full governor or RPM limiter (bottom right, shown without sensor), Aerospire MultiGov programming panel (bottom left)



RC Helicopter Primer

RC Helicopter Component Details

Power Systems

Servos

Helicopter Kits

Gyros

Governors

Automatic Mixture Controllers

Transmitters and Receivers

BECs / Voltage Regulators

Multi-Function Modules

Tools and Equipment

RC Helicopter Components

Automatic Mixture Control (1)

- A type of device that's become available relatively recently provides for *automatic mixture control*.
- Such a device helps to keep an internal combustion engine tuned through changing conditions, such as changes in...
 - engine load (gentle or aggressive maneuvers).
 - fuel pressure (as the tank drains, pressure tends to decrease).
 - ambient temperature (colder days, hotter days).
- This continuous tuning...
 - can maximize the engine's power output.
 - may extend the engine's life.

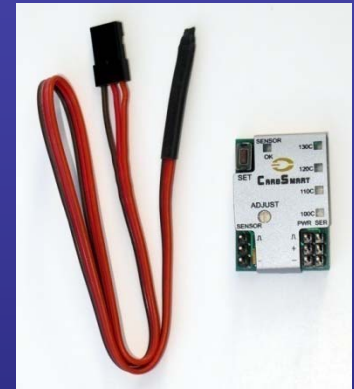

Above: CSM CarbSmart with sensor (top), Aerospire MultiGov Pro two-in-one governor and mixture controller (bottom)

RC Helicopter Components

Automatic Mixture Control (2)

- The mixture controller...
 - is programmed with a target engine temperature.
 - uses a temperature sensor that is attached to the engine.
 - continuously measures engine temperature.
 - employs a servo that is linked to the engine's fuel valve.
 - adjusts the fuel valve during flight, richening or leaning the mixture to keep the engine temperature at the preset value.
- The controller does not take over all engine tuning tasks.
 - Engines usually have multiple fuel control valves (e.g. one for the idle mixture, one for open throttle), and the mixture controller manages only one of them.
 - Initially, the engine still needs to be tuned manually for a tuning level that the mixture controller uses as a baseline.
- Automatic mixture control is not required for entry-level or even advanced RC helicopters.



Above: CSM CarbSmart with LEDs for temperature setting on right side (100°C to 130°C)



RC Helicopter Primer

RC Helicopter Component Details

Power Systems

Servos

Helicopter Kits

Gyros

Governors

Automatic Mixture Controllers

Transmitters and Receivers

BECs / Voltage Regulators

Multi-Function Modules

Tools and Equipment

RC Helicopter Components

Transmitters and Receivers

- Of course a radio controlled aircraft needs some sort of radio equipment.
 - A radio control transmitter (Tx) that is operated by the pilot.
 - A radio receiver (Rx) and battery that are on board the aircraft.
- The receiver connects to the servos (and ESC) on the aircraft and drives them to the positions commanded by the pilot.



Futaba 9CH (left), JR XP9303 (right)



Futaba R149DP (top left), JR R2000 (top right), HiTec Electron 6 (bottom left), typical 4-cell NiCd receiver battery (bottom right)

RC Helicopter Components

Tx / Rx: Two Technologies

- Most radio control equipment for model aircraft uses one of two radio frequencies:
 - 72MHz*
 - 2.4GHz
- Other types of remote control equipment work using...
 - infrared light for simple, short-range, indoor toys.
 - 27MHz for simple radio-controlled toys.
 - amateur radio frequencies (e.g. 50MHz; only for use by individuals who hold amateur radio licenses).
- 72MHz* radios have been the established technology for model aircraft.
- Most new radios employ 2.4GHz spread spectrum technology.

* 72MHz is the frequency for aircraft in the US; some other countries allocate different frequencies to radio controlled aircraft (e.g. 35MHz in Europe).

RC Helicopter Components

Tx / Rx: 72MHz Channels

- In the US, one of the primary radio systems for model aircraft...
 - operates in the 72MHz frequency range.
 - can use any one of 50 radio channels (11 through 60) in that frequency range.
- In other countries, RC aircraft equipment may operate in a different frequency range (e.g. 35MHz in Europe).
- Radio transmitters and receivers from different manufactures are not necessarily compatible, even if they operate on the same radio channel.
- Even when two pieces of equipment are not compatible, they can still interfere with each other if they are operating on the same channel.
- Pilots need to take care not to...
 - create mutual radio interference.
 - crash each other's models.
 - cause bodily injury or property damage with an out-of-control model.

RC Helicopter Components

Tx / Rx: 72MHz Frequency Control



Model Helicopter Insights™
RC Helicopter Primer

- RC clubs generally institute some frequency control system where every pilot has to check out his or her channel before using it.
- Especially at sites with no frequency control scheme, some pilots use frequency scanners to show which channels are in use and which are clear.
- Pilots should always exercise caution to avoid accidents due to radio interference!

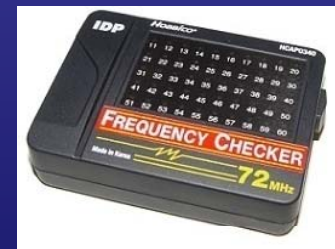

Above: Frequency control board at the Bayside RC Club where pilots check out frequency/channel pins before flying

Left: Hobbico frequency scanner

RC Helicopter Components

Tx / Rx: PPM vs PCM Signaling



Model Helicopter Insights™
RC Helicopter Primer

- One differentiator among pieces of 72MHz radio equipment is the signal encoding scheme.
- Two schemes exist for sending control signals from the transmitter to the receiver:
 - *Proportional Pulse Modulation (PPM)* *
 - *Pulse Code Modulation (PCM)*
- PCM systems...
 - use what is essentially a digitally encoded signal.
 - can suppress interference that would visibly affect an aircraft controlled through PPM.
 - provide fail-safe settings (e.g. throttle to idle) that are invoked if the receiver loses the transmitter's signal.
 - are different but not necessarily better than state-of-the-art PPM systems.

* PPM is sometimes referred to as frequency modulation (FM), although technically PPM and PCM are both FM-based.

RC Helicopter Components

Tx / Rx: PPM/PCM, Rx Types (1)



Model Helicopter Insights™
RC Helicopter Primer

- Many inconclusive discussions have been held about whether PPM or PCM is better.
 - Some PPM receivers perform advanced digital signal processing and offer noise rejection capabilities similar to PCM receivers.
 - Either technology can work fine if the aircraft's electrical system is set up cleanly.
- For PCM, the transmitter and receiver must be of the same brand; PCM devices from different manufactures are not interoperable.

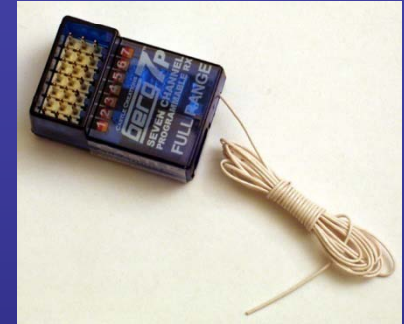

Above: Castle Creations' Berg-7 auto-shift PPM receiver with digital signal processing (Photo by W. Witt)

RC Helicopter Components

Tx / Rx: PPM/PCM, Rx Types (2)

- Even PPM may not work across different manufacturers.*
 - Futaba and Hitec, for example, employ *negative shift* modulation.
 - JR and Airtronics, for example, employ *positive shift* modulation.
 - Some manufacturers offer auto-shift PPM receivers that adapt to the transmitter.
- 72MHz receivers also differ in whether they are...
 - single conversion receivers.
 - double conversion (super heterodyne) receivers.
- Double conversion technology offers better signal filtering and adjacent channel rejection and should be less susceptible to interference.

* The negative/positive shift issue applies to 72MHz devices but may not apply to devices operating in other frequency bands.

RC Helicopter Components

Tx / Rx: 2.4GHz Spread Spectrum



Model Helicopter Insights™
RC Helicopter Primer

- In addition to 72MHz radio systems, *spread spectrum* technology has arrived.
- Spread spectrum systems...
 - operate in the 2.4GHz band (along with wireless networks, cordless phones and other devices).
 - use a signaling method that...
 - provides virtually interference-free radio links.
 - does not require channel control (i.e. people don't have to worry about transmitting on the same channel and crashing each other's aircraft).



Above: 2.4GHz spread spectrum transmitters: Spektrum DX7 (top left), JR X9303 2.4 (top right), Futaba T10CHP (bottom left), Airtronics RDS8000 (bottom right)

RC Helicopter Components

Tx / Rx: 2.4 GHz Antennas, Compatibility



Model Helicopter Insights™
RC Helicopter Primer

- 72MHz and 2.4GHz receivers use different antennas.
 - A 72MHz receiver has one relatively long (approximately 3ft or 1m) wire as an antenna.
 - A 2.4GHz receiver uses two short (usually 1 to 5in or 3 to 15cm) wires as antennas.
- The short 2.4GHz antennas...
 - typically need to be oriented at 90° relative to each other.
 - are easier to hide within a model (which is especially nice for scale models of full-size aircraft).
- Several manufacturers offer spread spectrum radio systems.
- Systems from different manufacturers are not compatible.*
 - They won't interfere with each other, but...
 - A transmitter from one manufacturer will not communicate with a receiver from another.

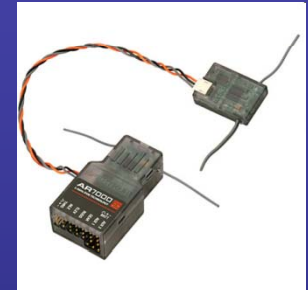

Above: 2.4GHz spread spectrum receivers:
Spektrum AR7000 (top),
Futaba R608FS (bottom)

* Spektrum brand radios and JR brand radios are an exception to this statement; they use the same 2.4GHz signaling scheme.

RC Helicopter Components

Tx / Rx: 2.4 Tx Conversion Modules

- Some 72MHz transmitters...
 - employ changeable modules for their radio frequency (RF) portions.
 - can be converted to 2.4GHz spread spectrum technology with new modules.
- Some believe that fully integrated systems (i.e. no module) are inherently superior to module-based systems.
 - The concern is over control delay or latency,* that is the time from the moment a pilot moves a transmitter stick until the signal arrives at the servos that control the aircraft.
 - Control latencies are roughly in the range of 20 to 90 milliseconds (i.e. 0.02 to 0.09 seconds).†
- Depending on the design and quality of the transmitter and the RF module, a module-based system can perform just as well as an integrated one.

* Control latency is typically not something a novice has to worry about, but the topic is covered here for completeness because latency is often the subject of heated discussion.

† Source: *TX/RX eCCPM Latency Test Results* by JKos (<http://www.runryder.com/helicopter/t172571p1>).



Above: Spektrum DM8 module for Futaba 9C transmitters (top), Futaba TM-8 FASST module for Futaba 9C transmitters (bottom)

RC Helicopter Components

Tx / Rx: Resolution



Model Helicopter Insights™
RC Helicopter Primer

- Some transmitter/receiver combinations advertise 1024 or 2048-step resolution.
 - Resolution is often quoted for PCM or spread spectrum radio systems.
 - When the radio gear translates transmitter stick motion to servo motion, the position signal is...
 - not a smoothly varying signal.
 - divided into a number of discrete steps that is large enough, so that the signal appears as if it is varying smoothly.
 - Higher resolution provides for finer and smoother position control.
- The actual resolution of a system is limited by the component with the lowest resolution.
 - If the radio link offers 2048 steps, but a servo is limited to 1024 steps, the overall resolution is 1024 steps (for the radio link to that servo).
 - If a servo capable of 2048 steps is used with a radio link that has only 1024 steps, the overall resolution is again 1024 steps.
- Some people confuse resolution with latency, but they are different.
 - Resolution measures how smoothly and finely position information can be transmitted.
 - Latency measures how quickly changes in position are transmitted from a transmitter stick to a servo.
 - Resolution and latency are largely independent.

RC Helicopter Components

Tx / Rx: Control Channels (1)



Model Helicopter Insights™
RC Helicopter Primer

- In addition to operating on a particular radio channel (72MHz channel or 2.4GHz spread spectrum link), a transmitter/receiver pair will offer a certain number of control channels.
- One control channel is required for each aspect of the aircraft that needs to be controlled.
 - Most control channels need to be proportional channels.
 - A proportional channel provides control over a range of values.
 - An engine throttle, for example, can be controlled smoothly to take any position between a minimum and a maximum.
 - For some channels, two simple states, on and off, suffice.
- Note that the word “channel” is being used in two different contexts:
 - radio channel in the 72MHz band
 - control channels within one radio channel

RC Helicopter Components

Tx / Rx: Control Channels (2)

- A collective pitch helicopter requires at least five channels:
 - Collective pitch
 - Throttle
 - Right/left cyclic pitch (aileron)
 - Fore/aft cyclic pitch (elevator)
 - Tail rotor pitch (rudder)
- Many helicopters use two more channels for dynamically...
 - controlling gyro mode (rate or heading hold) and gain (i.e. sensitivity).
 - setting the target speed of an IC-engine speed governor.
- For some applications (e.g. scale models), additional control channels may be needed for...
 - controlling the fuel mixture in flight.
 - retracting or extending a landing gear.
 - switching lights on and off.
 - operating a camera.

RC Helicopter Components

Tx / Rx: Channel Example



Model Helicopter Insights™
RC Helicopter Primer

- In the US, a radio controlled aircraft uses one of two types of radio links:
 - one of 50 radio channels in the 72MHz band
 - 2.4GHz spread spectrum

- Each radio link includes a number of control channels for different functions of the aircraft.
 - 72MHz channel 45 is shown here as an example, but the same is true for every other radio link.
 - another 72MHz channel
 - 2.4GHz spread spectrum link
 - The number of control channels shown here is 9, but the number of available control channels depends on the transmitter/receiver combination.
 - Different makes and models of radios may have different control channel assignments than the ones shown.

RC Aircraft Radio Frequencies and Channels (USA)

Channel	Frequency (MHz)	Channel	Frequency (MHz)	Channel	Frequency (MHz)
11	72.010	31	72.410	51	72.810
12	72.030	32	72.430	52	72.830
13	72.050	33	72.450	53	72.850
14	72.070	34	72.470	54	72.870
15	72.090	35	72.490	55	72.890
16	72.110	36	72.510	56	72.910
17	72.130	37	72.530	57	72.930
18	72.150	38	72.550	58	72.950
19	72.170	39	72.570	59	72.970
20	72.190	40	72.590	60	72.990
21	72.210	41	72.610		
22	72.230	42	72.630		
23	72.250	43	72.650		
24	72.270	44	72.670		
25	72.290	45	72.690		
26	72.310	46	72.710		
27	72.330	47	72.730		
28	72.350	48	72.750		
29	72.370	49	72.770		
30	72.390	50	72.790		

Control Channels within one Radio Channel

Channel	Futaba, Hitec	JR
1	Aileron, Right/Left Cyclic	Throttle
2	Elevator, Fore/Aft Cyclic	Aileron, Right/Left Cyclic
3	Throttle	Elevator, Fore/Aft Cyclic
4	Rudder	Rudder
5	Gyro Gain	aux
6	Collective Pitch	Collective Pitch
7	aux	Gyro Gain
8	aux	aux
9	aux	aux

RC Helicopter Components

Tx: Switches and Knobs (1)

- As discussed before, the left and right sticks of the transmitter are the primary controls for the aircraft.
- In addition to the sticks, transmitters...
 - have assorted switches (often four to eight).
 - may have additional...
 - knobs.
 - sliders.
- These switches, knobs and sliders can be...
 - assigned to control otherwise unused control channels.
 - programmed to affect primary control channels, such as throttle or collective pitch.

RC Helicopter Components

Tx: Switches and Knobs (2)



Switches

Example of transmitters' switches and knobs in addition to primary control sticks.

Some of these radios also have on their sides dials or sliders that are not visible here.

Knobs

Sticks

Spektrum DX7 transmitter (top left),
JR X9303 2.4 transmitter (bottom
left), Futaba 9C transmitter (right)

RC Helicopter Components

Tx: Switches and Knobs (3)

- The switches usually serve the following functions:
 - Throttle cut: shutting off the engine after a flight
 - Throttle hold: holding the engine at idle regardless of stick position
 - avoids accidentally throttling up while carrying the aircraft
 - provides a mechanism to perform auto-rations (landings without engine power), while retaining the option of bailing out and returning to powered flight
 - Flight mode selection (idle-up*): choosing between different pitch and throttle behaviors
 - normal flight, such as take-off, hovering, forward flight
 - aerobatics, such as inverted flight, loops, rolls
 - Gyro mode and gain: switching between rate and heading hold mode; changing gyro sensitivity
 - Governor RPM: changing governor target speed
 - Trainer mode: selecting whether the student or the teacher is in control during training flights
- The knobs and sliders are...
 - rarely used for pod-and-boom RC helicopters.
 - more applicable to scale models.

* “Idle-up” is a old term left over from less programmable radios, but it is still frequently used. With current radios, however, “idle-up” is really a misnomer and sometimes a cause of confusion.

RC Helicopter Components

Tx: Channel Counts and Features

- Different transmitters for RC aircraft offer between four to fourteen control channels.
 - Low-end devices typically have four to six channels.
 - Lower mid-range devices have seven or eight channels.
 - Upper mid-range devices typically have nine or ten channels.
 - High-end devices tend to have twelve to fourteen channels.
- Higher-end radios with more channels also tend to have...
 - better user interfaces and larger screens, making them easier to program.
 - more switches, knobs and sliders.
 - more electronic mixing options for different eCCPM swash plate geometries.*
 - more advanced programming functions (e.g. freely assignable switches, more flight modes, more points for pitch and throttle curves, channel mixers, timers).
 - more memory to store configurations for multiple aircraft.
 - nicer looking bodies or cases that may also be more comfortable to use.
- Because of their extra features and flexibility, high-end (e.g. 12 or 14-channel) radios...
 - are relatively complex to program.
 - may be overwhelming for new pilots.

* Most eCCPM helicopters employ 120° swash plates.

RC Helicopter Components

Tx: Interface Example: Menus



Model Helicopter Insights™
RC Helicopter Primer

Futaba T9CH Transmitter: Primary and Menu Screens:

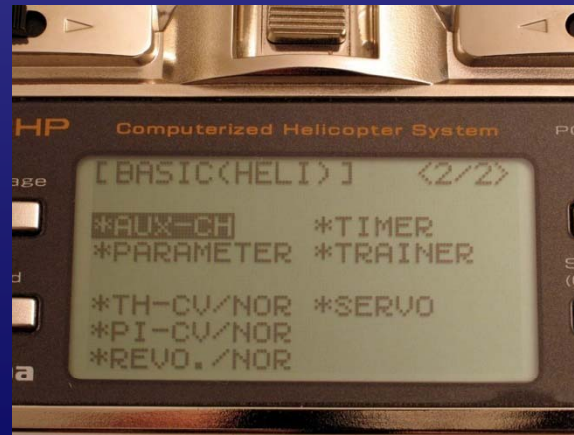
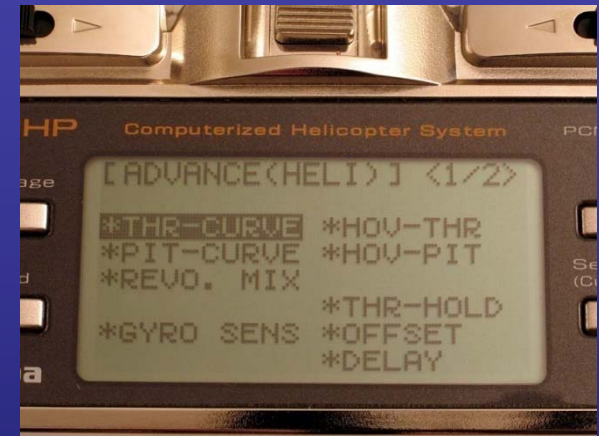

Futaba T9CHP transmitter: Primary screen showing select model (HawkPro), digital trims and timers (left); basic programming menu (middle); advanced programming menu (right)
(Photos by W. Witt)

RC Helicopter Components

Tx: Interface Example: Curves

Futaba T9CH Transmitter: Pitch and Throttle Curves Pairs for Three Helicopters:



Futaba T9CHP transmitter: Pitch and throttle curve pairs for three different helicopters (left to right); the right-most curve pair is for an electric helicopter with an ESC that is running in governor mode (Photos by W. Witt)

RC Helicopter Components

Tx: Airplane vs Helicopter



Model Helicopter Insights™
RC Helicopter Primer

- Although computer-based transmitters can be programmed to control airplanes as well as helicopters, most transmitters nevertheless come in airplane and helicopter varieties.
- Airplane and helicopter transmitters differ primarily in two ways:
 - whether the throttle stick has detents (airplane) or moves smoothly (helicopter).
 - whether switch locations (e.g. engine cut) follow engine or helicopter conventions.
- A throttle/collective stick with detents makes hovering a helicopter difficult as the ideal hover point may lie exactly between two of the positions the stick snaps to.
- Some transmitters can be modified to engage or disengage the detents as needed.

RC Helicopter Components

Tx: Transmitter for RC Helicopters



Model Helicopter Insights™
RC Helicopter Primer

- A helicopter transmitter should...
 - be a computerized transmitter.
 - not have detents on the left stick.
 - have at least six control channels (including a channel for remote gyro control).
 - be capable of eCCPM mixing (at least for 120° swash plates).
- If it's within the budget, a nine-channel transmitter...
 - is usually a good choice.
 - typically represents a good price/performance tradeoff.
 - offers a good balance between features and programming complexity.
 - provides adequate room for growth.



RC Helicopter Primer

RC Helicopter Component Details

Power Systems

Servos

Helicopter Kits

Gyros

Governors

Automatic Mixture Controllers

Transmitters and Receivers

BECs / Voltage Regulators

Multi-Function Modules

Tools and Equipment

RC Helicopter Components

Receiver Batteries and BECs

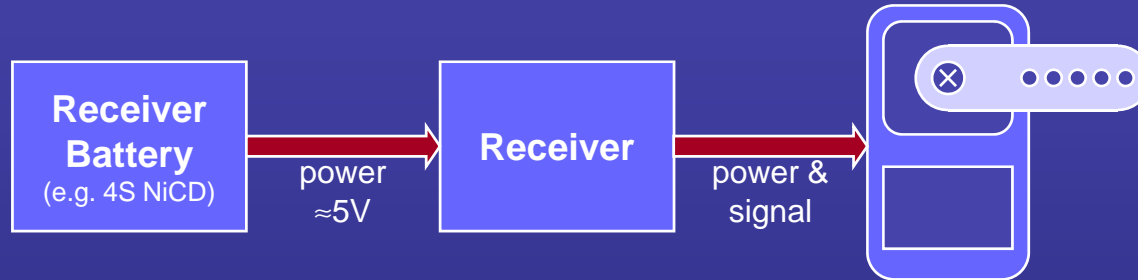

- Some sort of power supply is required to power the electronics on the aircraft.
- For an internal combustion-powered helicopter, receiver power comes from a small, dedicated battery.
- Receiver batteries are often four-cell NiCd batteries for roughly 5V (4.8V nominal).



Four-cell NiCd receiver packs in a flat (left) and square configuration (bottom).



RC Helicopter Components

Batt's and BECs: Separate Batteries



Model Helicopter Insights™
RC Helicopter Primer

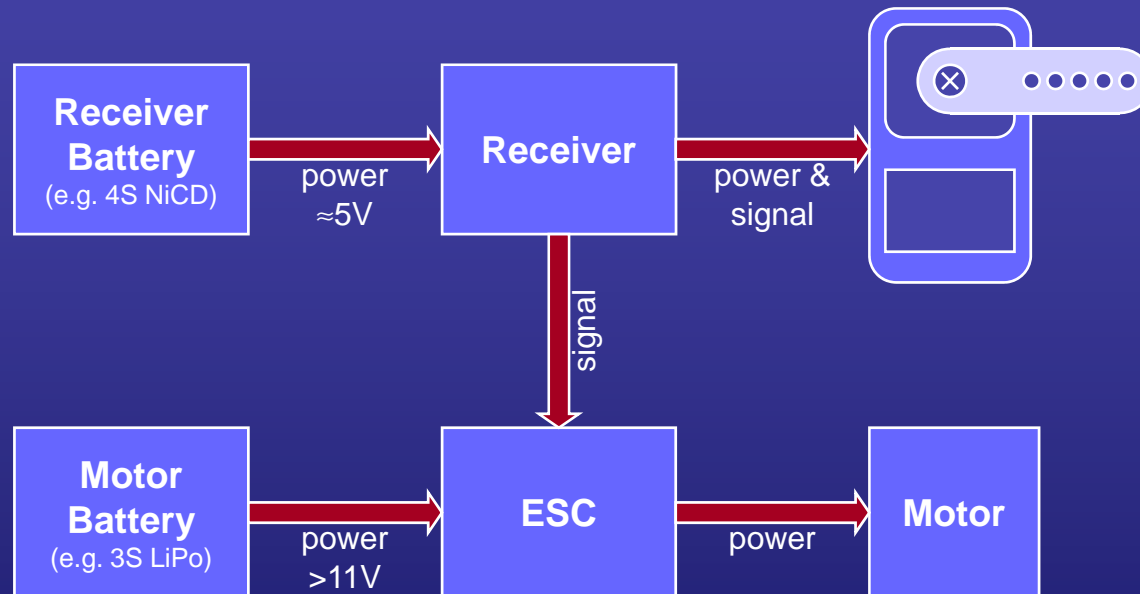

- On an electric helicopter, a large battery is required to power the motor.
- The motor battery is almost always of a higher voltage (e.g. a 3S LiPo for 11.1V) than the power supply required by the receiver.
- The receiver needs a power supply of 5V, so one approach is to have a separate 4S NiCd battery for the receiver.

RC Helicopter Components

Batt's and BECs: Single Battery

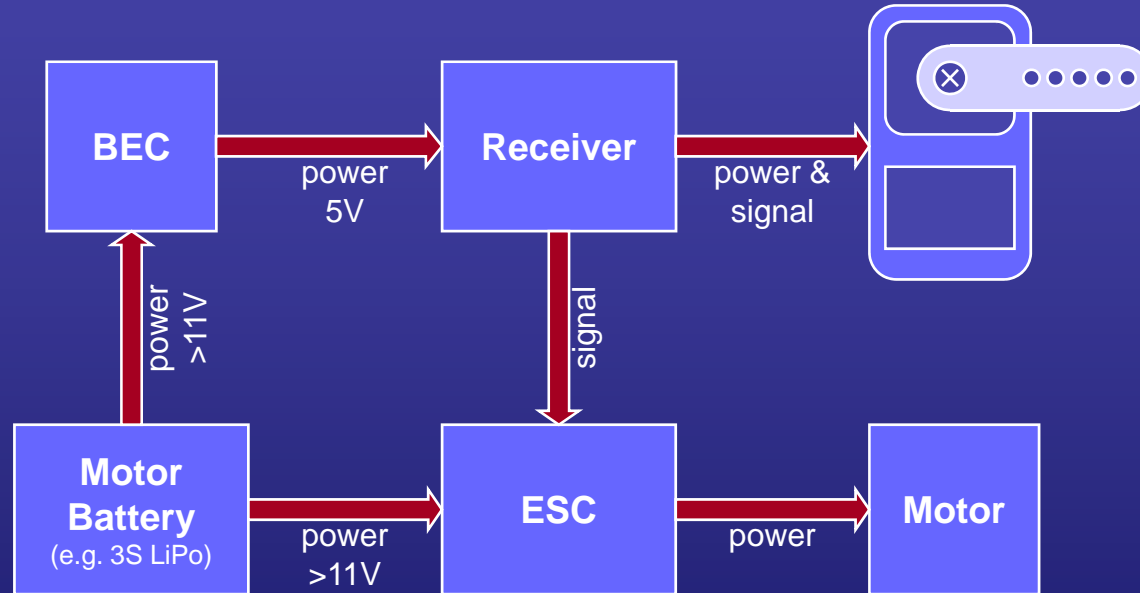

- Since a receiver battery adds weight, it may be replaced with a *battery eliminator circuit* (BEC).
- A BEC is a *voltage regulator* that takes power from the motor battery and regulates the motor battery voltage down to the voltage needed by the receiver (e.g. 11.1V to 5V).

RC Helicopter Components

Batt's and BECs: ESC with BEC

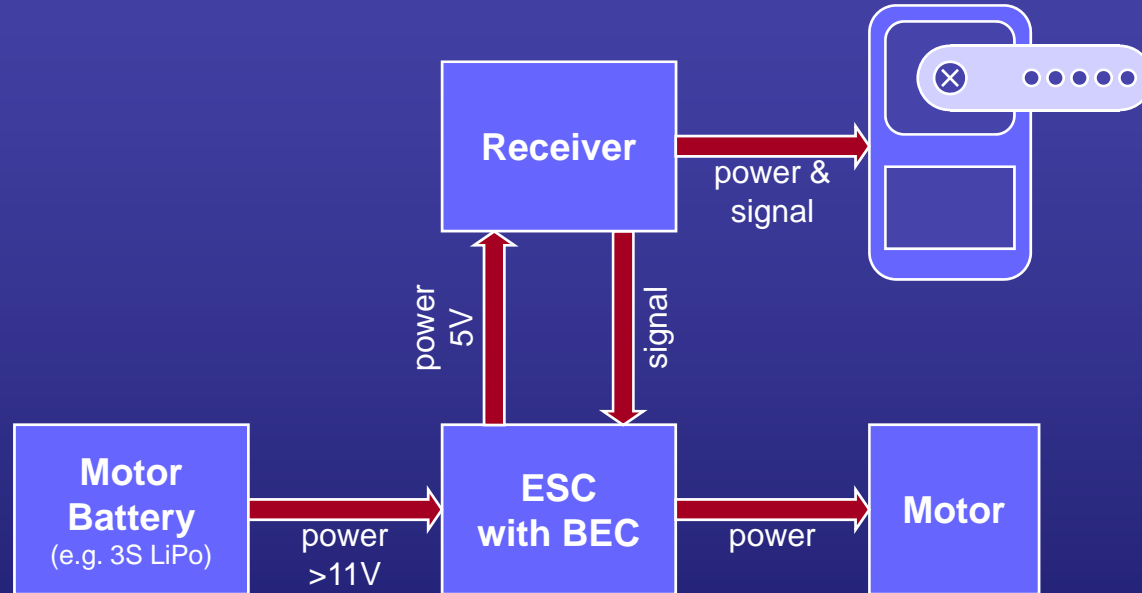

- Some ESCs have BECs built in.
- With such an ESC, the overall component and wire count is reduced.
- BECs integrated into ESCs, however, usually have less current capacity than stand-alone BECs, so a setup with many digital servos, for example, may still require a separate (and higher capacity) BEC.

RC Helicopter Components

BECs / V Regulators: Switching

- Battery eliminator circuits come in two flavors:
 - Switching voltage regulators
 - Linear voltage regulators
- Switching regulators...
 - work more efficiently with higher source voltages (e.g. 10V or more). *
 - minimum source voltage: target voltage + 0.5V (i.e. to power a receiver with 5V, the input voltage to the BEC needs to be at least 5.5V)
 - maximum source voltages: 35 to 60V
 - may generate electrical noise that may cause radio interference.
 - do not generate a lot of heat.



Above: switching voltage regulators (top to bottom): Castle Creation's BEC, Kool Flight System's Ultimate BEC and micro Ultimate BEC, SBEC

* The voltage numbers quoted here are only intended as a general guide; refer to a particular BEC's data sheet for specifics.

RC Helicopter Components

BECs / V Regulators: Linear

- Linear regulators...
 - work better if the source voltage is close to the target voltage (e.g. target voltage + 2V). *
 - minimum source voltage: target voltage + 0.5V
 - maximum source voltage: target voltage + 5V
 - do not generate electrical noise that could interfere with the radio link.
 - can generate quite a bit of waste heat, and this waste heat increases as...
 - the difference between source and target voltage increases.
 - current demand increases.
 - tend to have metal heat sinks.
- When BECs are integrated into ESCs, they are often linear regulators.

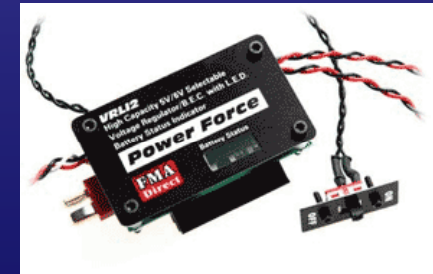

Above: linear voltage regulators (top to bottom): Arizona regulator from Fromeco, RCE-B6X regulator from Align, Power Force regulator from FMA Direct

* The voltage numbers quoted here are only intended as a general guide; refer to a particular BEC's data sheet for specifics.

RC Helicopter Components

V Regulators for IC Helicopters (1)

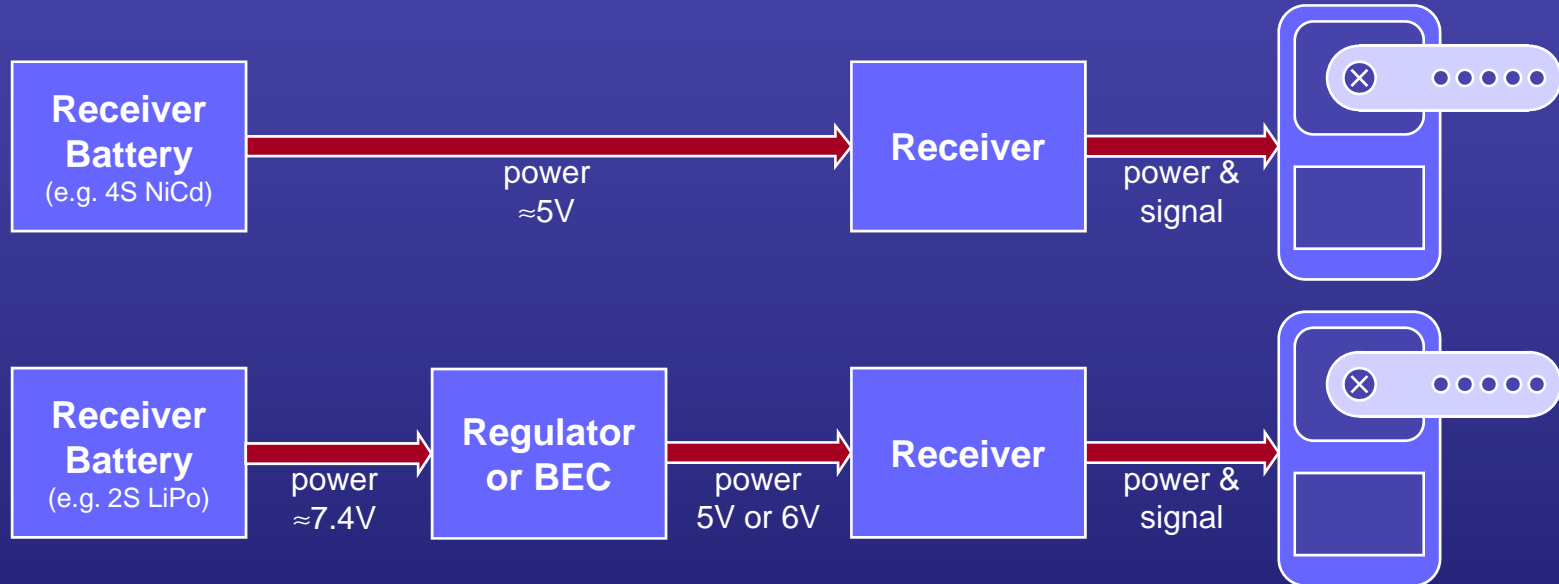

- Entry-level and intermediate internal combustion-powered helicopters may be set up, such that the receiver is powered directly from the receiver battery (top diagram above).
- Some intermediate and most high-performance IC helicopters are outfitted with BECs or voltage regulators,* and they may use 6V (or sometimes more) to power the receiver (bottom diagram above).

* In EP helicopters, voltage regulators are typically referred to as BECs; in IC helicopters, they're just called voltage regulators.

RC Helicopter Components

V Regulators for IC Helicopters (2)

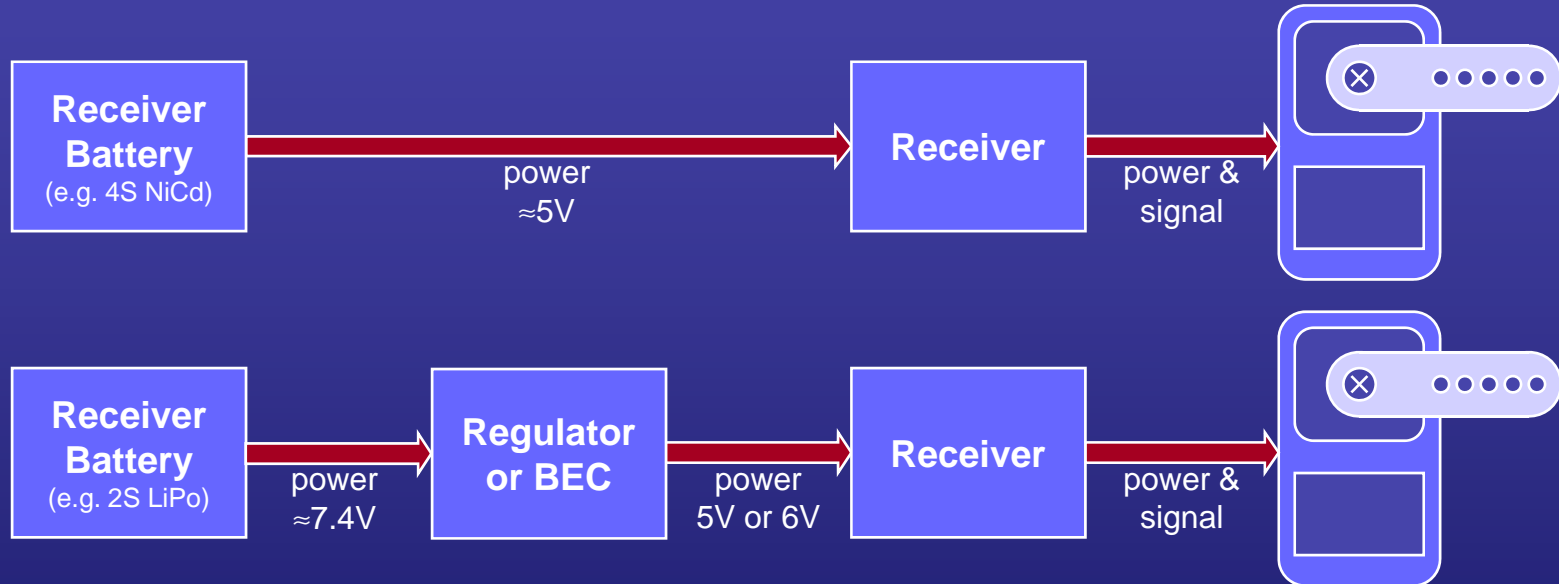

- The voltage regulator ensures that the receiver (and the servos) get a stable supply voltage even as servo (and current) load varies and the battery discharges.
- With a stable, regulated voltage, the helicopter's response will feel more consistent across different (especially aggressive) maneuvers.
- In this application the regulator is most commonly a linear regulator.

RC Helicopter Components

High-V Setups, Tail Servo Reg. (1)

- Some helicopter pilots power their swash plate (and throttle) servos with...
 - voltages greater than the standard 5V.
 - voltage levels of 5.8V, 6V, 7.4V or sometimes even 8V.
- Running the swash plate servos at a voltage greater than 5V...
 - increases their speed and torque.
 - makes the helicopter more responsive.
 - may damage servos that are not rated to operate at the higher voltage.



RC Helicopter Components

High-V Setups, Tail Servo Reg. (2)

- Tail servos...
 - are a special case.
 - tend to be very active as a gyro continuously makes corrections to hold a helicopter's tail steady.
 - can get hot.
 - are typically at risk of failure when operated at high voltages.
- Most tail servos need to be limited to about 5V (usually 5.1 or 5.2V max).

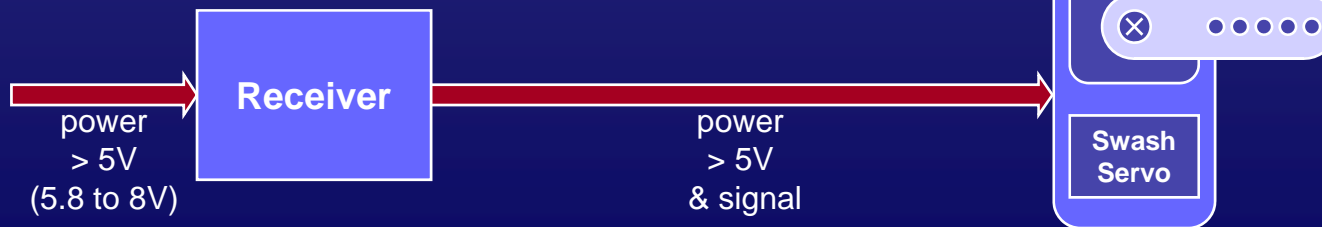

RC Helicopter Components

High-V Setups, Tail Servo Reg. (3)

- To make a high-voltage system work, the tail servo voltage must be reduced.
- A voltage regulator or voltage step-down...
 - is often placed between the gyro and the tail servo (as shown).
 - may sometimes be placed between the receiver and the gyro.

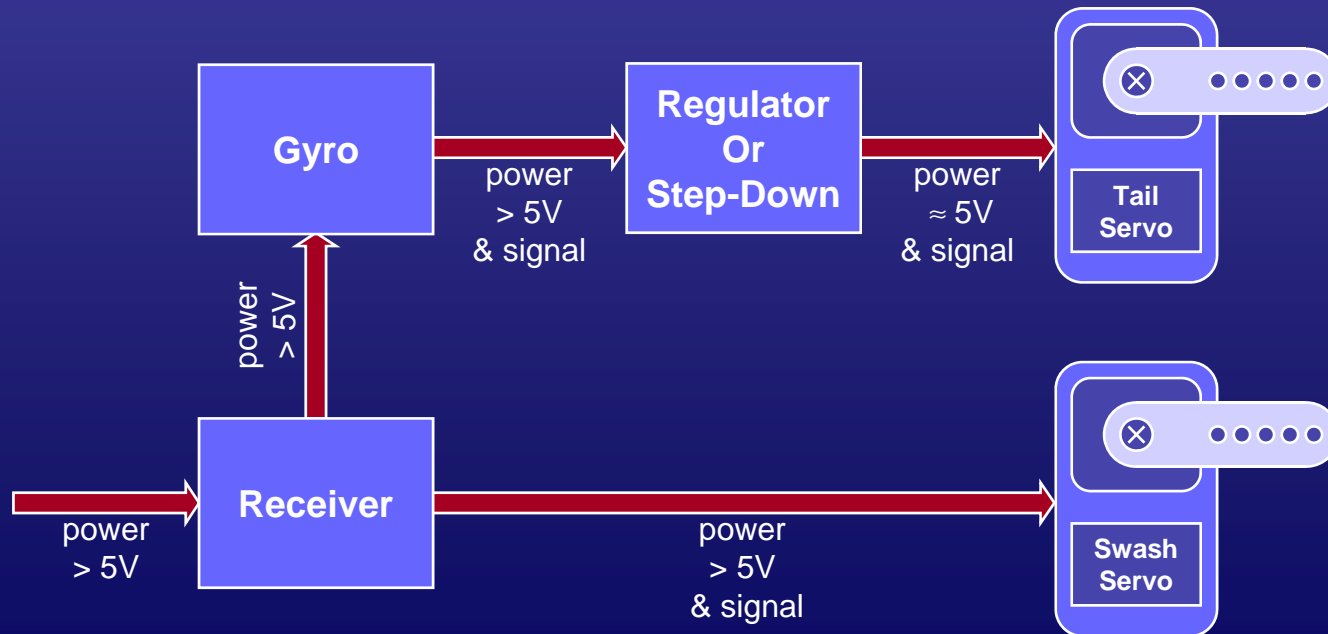

RC Helicopter Components

High-V Setups, Tail Servo Reg. (4)

- A tail servo's operating voltage typically needs to be limited to approximately 5V through a voltage...
 - step-down component.
 - regulator.
- A step-down (usually a diode)...
 - is not really a regulator.
 - simply drops the input voltage by about 0.7V (e.g. 5.8V is reduced to 5.1V).
- A regulator would be a linear regulator that can hold the output voltage at 5V for a range of input voltages.



Above: Align voltage step-down components (top left and top right), Western Robotics step-down (bottom left), Spektrum voltage regulator (bottom right)



RC Helicopter Primer

RC Helicopter Component Details

Power Systems

Servos

Helicopter Kits

Gyros

Governors

Automatic Mixture Controllers

Transmitters and Receivers

BECs / Voltage Regulators

Multi-Function Modules

Tools and Equipment

RC Helicopter Components

Multi-Function Modules

- Micro-helicopters frequently include electronic multi-function modules often called 2-in-1, 3-in-1 or 4-in-1 units.
- Such a unit integrates some (e.g. two, three or four) of the following functions into one unit.
 - Receiver
 - BEC
 - ESC
 - Gyro
- A particular 2-in-1, 3-in-1 or 4-in-1 unit tends to be customized for one particular electric helicopter.
- Such units are not suitable for larger helicopters (i.e. mini and above).



RC Helicopter Primer

RC Helicopter Component Details

Power Systems

Servos

Helicopter Kits

Gyros

Governors

Automatic Mixture Controllers

Transmitters and Receivers

BECs / Voltage Regulators

Multi-Function Modules

Tools and Equipment

RC Helicopter Components Equipment and Tools (1)

- RC helicopters require assorted...
 - tools and supplies for assembly.
 - tools for set up.
 - field equipment.
- The proper tools and equipment are likely to make the project of assembling, setting up, flying and maintaining a helicopter easier and more enjoyable.
- The following slides provide an overview of the gear that a new modeler and pilot may need for his or her RC helicopter (assuming it's not an RTF machine).
 - Some basic tools, equipment and supplies are most likely needed regardless of the type and size of helicopter.
 - Some will be specific to the type of helicopter (e.g. internal combustion power versus electric power).
 - Some are more advanced items.

RC Helicopter Components Equipment and Tools (2)

- Advanced tools...
 - may come in handy.
 - are probably not needed for an entry-level helicopter.
 - tend to be expensive and may not be worth the cost at the beginning.
- Experienced pilots at a club are likely to have these items and are usually happy to help new pilots.
- Instructions for using the tools are beyond the scope of this presentation.
 - The instructions accompanying a tool are one resource.
 - The helicopter assembly manual may give some guidance.
 - Experienced modelers should be able to help.

RC Helicopter Components

Equipment and Tools: Assembly (1)

- Common tools for assembly:
 - Phillips screw driver
 - Metric hex drivers and allen wrenches (usually 1.5 to 4mm) *
 - Metric nut drivers (usually 2 through 4mm; for IC engines also 8mm glow plug wrench and 10mm wrench for drive shaft nut) *
 - Ball link pliers (special model helicopter tool)
 - Needle-nose pliers
 - Sharp hobby knife (e.g. X-Acto knife)
- More specialized tools for assembly:
 - Small drilling, grinding and cutting tool (e.g. Dremel tool)
 - Snap-ring pliers (for models that employ snap rings) †
 - Crank shaft or piston lock (for IC engine) ‡
 - Soldering iron and soldering supplies (for EP helicopters)

* Almost all helicopter kits and parts use metric units; rarely is something based on English units.

† Snap-ring pliers aren't strictly necessary but make assembly (and especially disassembly) a lot easier.

‡ A piston locking tool can sometimes damage an engine; a crank shaft locking tool is preferred.

RC Helicopter Components

Equipment and Tools: Assembly (2)



Above: ball link pliers (top), snap ring pliers (bottom), engine crank shaft locking tool (left)

Left: Century starter tool kit including pitch gauge, ball link pliers, hex drivers and allen wrenches, nut drivers, 4-way wrench, Philips screw driver

RC Helicopter Components

Equipment and Tools: Assembly (3)



Model Helicopter Insights™
RC Helicopter Primer

- Additional basic assembly supplies and accessories:
 - Cyanoacrylate (CA) glue
 - Medium strength thread locker (e.g. blue Loctite 242 or 243)
 - Double-sided adhesive tape (e.g. Scotch foam mounting tape)
 - Cable ties (a.k.a. zip ties; for securing avionics components and wires)
 - Velcro ties (for securing avionics components and wires)
 - Tri-Flow oil (to lightly lubricate sliding parts)
 - Rubber bands (medium width)
- More specialized supplies and accessories:
 - Medium speed (15 to 30-minute) epoxy
 - Metal-based epoxy (e.g. J-B Weld)
 - Foam wrap (to wrap electronic components like the receiver and protect them from vibration, especially in IC helicopters)
 - Lithium grease (for some tail rotor gearboxes)
 - Spare fuel tubing (medium size for glow fuel; may also be useful for protecting a receiver's antenna wire from chafing)

RC Helicopter Components Equipment and Tools: Assembly (4)



Left (counterclockwise): Tri-Flow lubricant, Great Planes epoxy, J-B Weld metal-based epoxy, Pacer Zap-A-Gap CA glue, Great Planes CA glue, Loctite 242 blue medium-strength thread locker



Top: Du-Bro protective foam

Left: zip ties (left most, top right), velcro tie (bottom right)

RC Helicopter Components

Equipment and Tools: Setup (1)

- Tools for set up:
 - Rotor blade balancer
 - Calipers (preferably digital calipers)
 - Rotor blade pitch gauge (for collective pitch machines)
 - Small bubble levels (e.g. line levels)
 - Blade tracking tape



Above left (top to bottom): Miniature Aircraft main rotor blade pitch gauge, Heli-Max pitch gauge, digital caliper, small bubble levels, Heli-Max blade tracking tape

Above right (top to bottom): KSJ blade balancer, Kyosho blade balancer, Century blade balancer

RC Helicopter Components

Equipment and Tools: Setup (2)

- Advanced tools for setup:
 - Ball link sizing tool (for loosening tight links)
 - Tachometer (for measuring rotor speed)
 - Thermometer (for checking engine or motor temperature)
 - Watt meter or on-board data recorder (for measuring the performance of an electric helicopter's power system)



Above: ball link sizing tool from JR or Century (top left), Miniature Aircraft rotor tachometer (top middle), Model Avionics tachometer (top right, photo by W. Witt), thermometers (middle left and center), Eagle Tree Micro Power data logger (middle right), RC Electronics' Watt's Up power meter (bottom left, photo by W. Witt), Medusa Research Power Analyzer power meter (bottom right)

RC Helicopter Components

Equipment and Tools: Field (1)

- Support and field equipment for IC helicopter:
 - Receiver battery tester
 - Fuel jug and fuel pump
 - Glow plug heater (a.k.a. glow driver)
 - Electric starter with 12V to 24V battery
 - Cleaning supplies (e.g. denatured alcohol and paper towels)
 - Spare glow plugs
- Additional field equipment:
 - Frequency scanner (to avoid radio interference in 72MHz band at flying sites with no frequency control system)
- Support and field equipment for EP helicopter:
 - Smart, multi-purpose, high-capacity battery charger
 - High-capacity 12V field battery (optional)
 - Appropriate charge leads
- A good battery charger is also advantageous for IC helicopters to...
 - charge batteries quickly and safely.
 - Transmitter battery
 - Receiver battery
 - Starter battery
 - potentially extend battery life.

RC Helicopter Components Equipment and Tools: Field (2)



Above: Hobbico 72MHz radio channel scanner



Above (left to right): receiver battery testers: MPI, Futaba, Power Mate, Hobbico

Below: Century field equipment starter pack for glow helicopters including engine starter, starter battery with charger, manual fuel pump, glow plug heater with charger



Below: battery chargers: ElectrIFly Triton (top left), Schulze isl 6-330d (top right), Orbit Microlader (bottom left), Accu-Cycle Elite (bottom right)

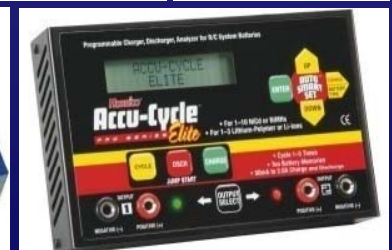

RC Helicopter Components

Equipment: Battery Chargers

- Note that different battery types (e.g. NiCD, NiMH, LiIo, LiPo, Lead, etc.) require different charging procedures.
 - Charging a battery with the wrong charging method can ruin the battery and may lead to a fire!
 - Most modern, general purpose chargers are computer controlled and can be programmed for different battery types.
- Especially LiPo batteries require careful handling.
 - Over-charging or over-discharging can lead to fires.
 - The voltages across the different cells of a battery may become unbalanced...
 - such that the battery overall may appear healthy, but...
 - one cell is at risk of reaching too high or too low a voltage during normal use.
 - Special cell balancers are available and should be used to keep the cells of LiPo batteries in balance.
 - Some chargers have balancers built in.

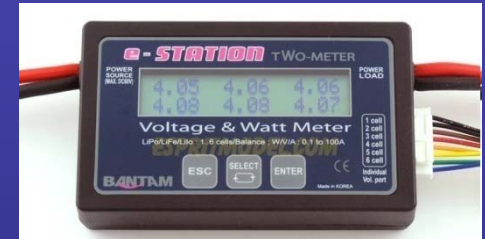

Above: LiPo cell balancers: Thunder Power TP-210V balancer (left), Bantam e-Station Two-Meter balancer, battery tester and watt meter (right)



Below and right: balancing chargers: FMA Cellpro lithium charger (right), Hyperion EOS0610i multi-function charger (bottom left), Bantam e-Station BC6-10 multi-function charger (bottom right)



RC Helicopter Components

Equipment: Chargers, Field Batteries

- Smart battery chargers for RC model applications typically...
 - do not plug into wall (120V AC) outlets.
 - need to be powered from a 12V DC source.
- The 12V DC source may be...
 - a car battery. *
 - a separate, high-capacity 12V sealed lead acid (SLA) battery (where “high capacity” should probably be at least 40 Ah to charge large LiPo flight packs).
 - a regulated 120V AC to 12V DC (actually 13.8V DC) power supply capable of delivering 10 to 40A depending on the charger and the intended application.



Above: Thunder Power 1010C Lithium charger (left), ElectriFly Triton-2 charger (right)



Above: high-capacity sealed lead acid batteries: PowerSonic (left), Universal Battery (right)



Above and right: 12V DC regulated power supplies: BK Precision 40A (top left), Samlex 20A (top right), Pyramid 25A (bottom right)



* Caution: Car batteries are usually not intended to be deeply discharged.

RC Helicopter Components

Equipment: Training

- Gear to help with learning to fly:
 - Extended landing gear (a.k.a. training gear)
 - Trainer cord to connect two transmitters together for a buddy box setup
 - RC flight simulator
- A simulator...
 - is an excellent training aid at the beginning.
 - great for trying out advanced maneuvers later.
 - good for practicing at night or when the weather is bad.
- Some simulators come with controllers, some work with your transmitter.



Above: Assembled extended helicopter landing gear (left), parts of Century helicopter training gear (right)



Above: Reflex XTR (top right), Phoenix RC (right middle), RealFlight G3.5 (bottom right), AeroFly Pro Deluxe (bottom middle), ClearView (bottom left)

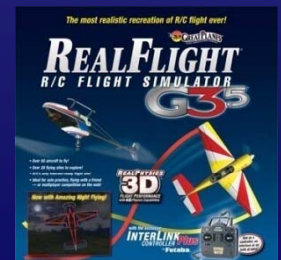



RC Helicopter Primer

End of RC Helicopter Component Details

Power Systems

Servos

Helicopter Kits

Gyros

Governors

Automatic Mixture Controllers

Transmitters and Receivers

BECs / Voltage Regulators

Multi-Function Modules

Tools and Equipment



RC Helicopter Primer

Tips to Get Started

Helicopter Selection
Helicopter Assembly
Helicopter Setup and Checkout
First Flights
Simulator Practice



RC Helicopter Primer

Tips to Get Started

Helicopter Selection
Helicopter Assembly
Helicopter Setup and Checkout
First Flights
Simulator Practice

Tips to Get Started

Helicopter Selection: Advice (1)

- One key question is what size of helicopter to start with?
- Advice commonly dispensed to prospective RC helicopter pilots includes:
 - Start with a coaxial fixed pitch helicopter.
 - Start with a fixed pitch helicopter (micro or mini).
 - Start with a collective pitch micro helicopter.
 - Start with a collective pitch mini helicopter ($\approx 300\text{mm}$ blades).
 - Start with a 30-size collective pitch helicopter ($\approx 550\text{mm}$ blades).
 - Start with a 50-size helicopter ($\approx 600\text{mm}$ blades).
 - Start with a 60-size helicopter.
- The only common thread in this advice is that nobody really recommends a new pilot to start with a 90-size machine.*

* Although a 90-size is often just a 60-size with a bigger engine and some upgrades.

Tips to Get Started

Helicopter Selection: Advice (2)

- Start with a coaxial fixed pitch helicopter?
 - Most likely available as a ready-to-fly (RTF) package including a basic transmitter.
 - Very stable and good for orientation practice (e.g. side in, nose in).
 - Can fly in relatively small indoor spaces; not suitable for outdoors.
 - Not very upgradeable.
- Start with a fixed pitch helicopter (micro or mini)?
 - Possibly available as an RTF package including a basic transmitter.
 - Tends to sustain less damage during a crash than a collective pitch machine and may therefore be cheaper as a trainer.
 - Likely to feel unstable; probably quite challenging to hover.
 - Likely to be difficult to fly in windy conditions.
 - Not capable of inverted flight.
 - Probably not very upgradeable.

Tips to Get Started

Helicopter Selection: Advice (3)

- Start with a collective pitch micro helicopter?
 - Probably available as an RTF or ARF package (including motor and ESC) and may include a basic transmitter.
 - Likely to feel unstable; probably quite challenging to hover.
 - May be flown in medium-sized indoor spaces or outdoors if wind is light.
 - May be capable of aerobatics (e.g. inverted flight).
 - Should be somewhat upgradeable.
- Start with a collective pitch mini helicopter (≈ 300 mm blades)?
 - Most likely offered as a kit.
 - A motor and ESC (and sometimes a battery) may be included.
 - Avionics (receiver, servos, gyro) may need to be purchased separately.
 - May be relatively stable despite the small size.
 - May be flown in large indoor spaces (e.g. a gymnasium) or outdoors.
 - Most likely capable of basic to intermediate aerobatics.
 - Replacement parts should be relatively affordable.
 - Numerous upgrade parts tend to be available.

Tips to Get Started

Helicopter Selection: Advice (4)

- Start with a 30-size* collective pitch helicopter (≈550mm blades)?
 - Will be an ARF or a kit.
 - Avionics will probably need to be purchased separately.
 - An engine and a basic muffler (for IC power), or a motor and an ESC (for electric power) may be included.
 - Should be significantly more stable in a hover than micro and mini helicopters.
 - Most likely capable of basic to intermediate aerobatics (inverted flight, etc.).
 - Replacement parts tend to be affordable.
 - Upgrades tend to be readily available (including upgrades to convert to a 50-size).
- Start with a 50-size helicopter (≈600mm blades)?
 - Almost always a kit, usually not available as an ARF.
 - Avionics will need to be purchased separately.
 - Sometimes available in packages that include...
 - a high-performance engine, muffler and governor (for an IC-powered helicopter).
 - a good motor and ESC (for an EP helicopter).
 - More stable and more powerful (i.e. higher power to weight ratio) than a 30-size.
 - Likely capable of advanced aerobatic maneuvers.
 - Starting with a 50-size may be more cost effective than upgrading a 30-size, especially if the crash rate will be low.
 - Parts and upgrades tend to be readily available and relatively affordable.

* 30-size helicopters have somewhat faded away in favor of 50-size machines.

Tips to Get Started

Helicopter Selection: Advice (5)

- Start with a 60-size* helicopter?
 - Most definitely a kit.
 - A 60-size can be much more stable than all the smaller helicopters.
 - The large size may be intimidating for a new pilot.
 - Parts costs will be relatively high.
 - Most likely upgradeable to a 90-size.
- Start with a 90-size helicopter?
 - Virtually no one would recommend this approach to a new pilot.
 - The initial cost of the kit will be high.
 - Like a 60-size...
 - the machine may be quite intimidating.
 - parts costs will be high.
 - The fuel consumption rate is high (maybe only six flights per gallon of fuel), so even without crashes, this type of machine would be an expensive trainer.

* 60-size helicopters have mostly faded away in favor of 90-size machines.

Tips to Get Started

Heli Selection: Your Choice

- In general...
 - Fixed pitch helicopters are relatively robust but do not offer a long-term growth path.
 - Smaller helicopters tend to be less intimidating than larger ones.
 - Larger helicopters tend to be more stable and are less affected by wind, while smaller ones tend to require more skill and effort to control them.
 - Larger helicopters burn more fuel or require bigger (more expensive) batteries than smaller helicopters.
 - Replacement parts tend to get more expensive as helicopter size increases.
 - Upgrades are typically not required to get a helicopter that's suitable for learning hovering and the basics of flight.
- Bottom line:
 - There is no single best way to get started.
 - Understand the tradeoffs, ask your own questions and make your own decision.

Tips to Get Started

Heli Selection: Some Questions

- Some questions to think about...
- Do you just want to try out the hobby or are you reasonably sure you'll stick with it for the long haul?
- Where will you be able to fly your helicopter?
 - Indoors? In a park? At a club?
 - How large is the space?
 - Is IC engine noise ok?
- How fast do you tend to learn new skills that require fine hand-eye coordination?
- Are you a patient, step-by-step kind of person, or do you tend to be more aggressive (and therefore perhaps likely to crash more often)?
- What's the largest helicopter that will fit into your car?
- What are other pilots in your area flying?
- What products do hobby shops in your area carry?
- What is your budget (for the initial purchase and for repairs)?
- What level of skill are you planning to attain?
(Sport flying? Mild aerobatics? Aggressive aerobatics or 3D?)

Tips to Get Started

Heli Selection: Likely Cost

- RTF packages of micro helicopters tend to be priced in the neighborhood of \$200 to \$300.
- For other ARFs and kits that require separate components, the start-up cost tends to be at least \$1000 (possibly less, easily more)
 - The typical price range is \$800 to \$1500, possibly up to \$2000.
 - This price includes a decent transmitter, receiver, servos, gyro, engine, batteries, tools, etc.
 - A good transmitter is a long-term investment and can be re-used for additional, future helicopters (or planes).
- Beware of suspiciously cheap helicopters (e.g. \$200 for something that costs much more elsewhere).
 - You will most likely get what you pay for.
 - not a very good helicopter; maybe a decent helicopter frame with poor avionics
 - a helicopter that requires a lot of upgrades before it flies decently
 - Helicopters from overseas sometimes ship with the wrong mode transmitter (i.e. Mode 1 instead of Mode 2).

Tips to Get Started

Heli Selection: Not The Very Best (1)



Model Helicopter Insights™
RC Helicopter Primer

- For your first helicopter, you do not need the very best.
- An especially expensive, high-end helicopter may actually slow your progress.
 - A high-end helicopter tends to be a very responsive aircraft, but a new pilot needs a machine that's more docile.
 - Often, a helicopter's sensitivity can be tuned down (e.g. through a slower rotor speed, heavier fly bar paddles, softer rotor head dampers, transmitter expo).
 - Still, sometimes new pilots end up with machines that they find too stressful to fly.
 - An expensive helicopter may be more intimidating to fly because it will be expensive to fix after a crash.
 - You may be more nervous about making mistakes, and that nervousness may lead to crashes.
 - Because of the intimidation factor, you may be less inclined to try new maneuvers.
- You will most likely not realize the potential of a super fancy helicopter for some time; from your perspective, a less fancy machine will probably fly just as well (or perhaps even better).

Tips to Get Started

Heli Selection: Not The Very Best (2)

- Stuff you don't need for your first helicopter:
 - carbon fiber parts
 - carbon frames → glass fiber is quite good; plastic is fine, too
 - carbon tail boom → even high-end helicopters often employ aluminum booms
 - carbon rotor blades → wood blades work great for hovering, forward flight and even beginning aerobatics
 - carbon fly bar paddles or carbon tail rotor blades → plastic works just fine
 - full metal rotor head → even with some plastic parts (e.g. mixing levers, blade grips) rotor heads can still be high-precision mechanisms
 - lithium battery with voltage regulator to power the receiver (for an IC helicopter) → a 4-cell (or maybe 5-cell) NiCD battery is sufficient
 - top-end gyro → a mid-range heading hold gyro (e.g. Futaba GY401) will work great, a top-end gyro (e.g. GY611) is overkill
 - virtual fly bar → mechanical fly bars work perfectly well and are easier to set up; an electronic fly bar is not likely to make learning easier

Tips to Get Started

Heli Selection: Not The Very Best (3)

- Stuff you don't need for your first helicopter (cont):
 - high-end digital servos → except for aggressive aerobatics, high-end servos won't perform noticeably better than good mid-range servos
 - one particular high-end, digital servo offers 0.90 sec/60° and 160 oz·in (at 4.8V) and costs more than \$100, but such servos are not required
 - for a 50-size (≈600mm blade) machine, digital servos of approximately 0.15 sec/60° and 100 oz·in should be more than sufficient for most styles of flight
 - even somewhat slower and weaker servos or possibly analog servos can be fine for swash plate control (but do put a fast digital servo on the tail)
 - speed governor (especially for an IC helicopter) → program throttle curves into the radio (which should be done anyway)
 - automatic mixture control (for IC helicopter) → provides only a small benefit over a properly tuned engine; does not fix bad tuning
 - 30% nitromethane fuel → 15% or 20% fuel should be sufficiently powerful even for beginning aerobatics

Tips to Get Started

Heli Selection: Used Helicopters

- Used (pre-owned? pre-flown?) helicopters may be available at...
 - your local RC modeling club.
 - on-line discussion boards that include for-sale sections.
 - on-line auction sites.
- A used helicopter may be a good choice, but purchasing such a machine also poses risks.
 - Many on-line sellers are reputable, but some are not.
 - Even if the seller claims that the helicopter flies fine, it may in fact...
 - not be set up correctly.
 - require repairs or upgrades to work properly and safely.
- If possible, prior to purchasing a used helicopter...
 - have the seller demonstrate that the helicopter flies.
 - have someone who knows helicopters...
 - check it out and test fly it for you.
 - inspect the inside of the engine (if applicable) to make sure it is in good condition.

Tips to Get Started

Heli Selection: Transmitter (1)

- Unless you've chosen a helicopter that includes a basic radio transmitter, you'll need to choose and purchase one.
 - You'll need a transmitter that offers at least six control channels.
 - A nine or ten-channel radio may be a nice starting point, as it will...
 - have a better user interface.
 - be more programmable.
 - offer more room to grow.
- Some vendors offer package deals that bundle a transmitter with a mini or 30-size helicopter.
 - In most cases, such a transmitter will be a six or seven channel unit.
 - Make sure it's a transmitter you actually want (i.e. not too cheap or too basic).

Tips to Get Started

Heli Selection: Transmitter (2)



Model Helicopter Insights™
RC Helicopter Primer

- For new radio gear, a 2.4GHz spread spectrum radio system is the system of choice, as it eliminates concerns over radio channels and reduces the risk of radio interference.
- If you're purchasing a 72MHz radio system, consider whether you care about the radio channel.
 - If you don't ask for a specific radio channel, you'll end up with a channel at random (one of the channels between 11 and 60).
 - If you're going to fly where others fly (e.g. at a club), consider checking what channels are less used and asking for one of those.
 - Some high-end systems include frequency synthesizers that offer user-selectable radio channels.

Channel	Frequency (MHz)	Channel	Frequency (MHz)	Channel	Frequency (MHz)
11	72.010	31	72.410	51	72.810
12	72.030	32	72.430	52	72.830
13	72.050	33	72.450	53	72.850
14	72.070	34	72.470	54	72.870
15	72.090	35	72.490	55	72.890
16	72.110	36	72.510	56	72.910
17	72.130	37	72.530	57	72.930
18	72.150	38	72.550	58	72.950
19	72.170	39	72.570	59	72.970
20	72.190	40	72.590	60	72.990
21	72.210	41	72.610		
22	72.230	42	72.630		
23	72.250	43	72.650		
24	72.270	44	72.670		
25	72.290	45	72.690		
26	72.310	46	72.710		
27	72.330	47	72.730		
28	72.350	48	72.750		
29	72.370	49	72.770		
30	72.390	50	72.790		

Tips to Get Started

Helicopter Selection: Summary* (1)



Model Helicopter Insights™
RC Helicopter Primer

- A small RTF helicopter (e.g. a coaxial rotor micro helicopter)...
 - can be a good introduction to RC helicopters.
 - is great for bumping around house.
 - may get old fast.
- To seriously get started in the RC helicopter hobby, start with...
 - a collective pitch helicopter.
 - a helicopter that's...
 - not too small to be too difficult to control, or too large to be too intimidating or expensive.
 - either a mini (blade length no less than 300mm), 30-size (550mm blade length) or maybe 50-size (600mm blade length) machine.
- Consider a glow fuel-powered machine (30 or 50-size) to...
 - keep the startup cost low (by not having to buy multiple, expensive batteries).
 - allow for more consecutive training flights without having to recharge batteries.

* Some of the advice on this slide is just Wolf's opinion. Others may offer different opinions.

Tips to Get Started

Helicopter Selection: Summary* (2)



Model Helicopter Insights™
RC Helicopter Primer

- Don't be too aggressive at the beginning.
 - Don't start with the hottest aerobatic (i.e. "3D") machine you can find, even though such a helicopter may look great in an advertisement or on a store shelf.
 - Begin with a helicopter that's a stable performer for a new pilot.
 - A high-end 3D helicopter may be too sensitive to work well as a trainer.
- Don't worry about upgrades; get them when you really need them, after you've developed your basic skills (and gotten your initial crashes out of the way).
 - Wooden main rotor blades will work fine for quite some time.
 - Carbon fiber frame and metal head components are not required at the beginning; plastic is likely to work well.
- For a glow fuel powered machine, start out with a fuel that has relatively low (e.g. 15%) nitromethane content.
 - Less nitromethane saves money.
 - The extra power of more nitromethane won't matter for a while.

* Some of the advice on this slide is just Wolf's opinion. Others may offer different opinions.

Tips to Get Started

Helicopter Selection: Summary* (3)



Model Helicopter Insights™
RC Helicopter Primer

- Don't go overboard with fancy (expensive) servos.
 - Digital servos for collective and cyclic (i.e. swash plate) control...
 - are nice as they provide more control precision.
 - are not absolutely necessary.
 - Good analog servos can work fine for collective and cyclic and especially throttle control.
 - Do consider a digital servo (with a matched gyro) for tail pitch control.
- Consider keeping the receiver power supply simple.
 - A voltage regulated system is not required for an entry-level machine.
 - A good, four-cell NiCD battery (for a 30 or 50-size machine: 1000mAh with analog servos, 1500 to 2000mAh with digitals) will provide adequate power.
 - A new battery and regulator can easily be added later.

* Some of the advice on this slide is just Wolf's opinion. Others may offer different opinions.

Tips to Get Started

Helicopter Selection: Summary* (4)



Model Helicopter Insights™
RC Helicopter Primer

- If possible, invest in a...
 - good transmitter (7 to 10 channels, not necessarily for the channels but for the programmability and general usability of the radio).
 - a good heading-hold gyro (ideally with a matched digital tail servo).
- Avoid super cheap deals (you're likely to get exactly what you paid for) but neither should you need the most expensive, high-end components.
- Even though it will take longer to get into the air, strongly consider buying a kit and assembling the helicopter yourself, in order to learn more about the machine.
- Allocate some money for...
 - repairs after crashes.
 - an RC flight simulator.

* Some of the advice on this slide is just Wolf's opinion. Others may offer different opinions.



RC Helicopter Primer

Tips to Get Started

Helicopter Selection
Helicopter Assembly
Helicopter Setup and Checkout
First Flights
Simulator Practice

Tips to Get Started

Helicopter Assembly (1)

- Assembling a kit or even an ARF...
 - will be very educational.
 - is likely to present some challenges and opportunities for four-letter words and colorful phrases.
 - almost always takes longer than the assembly time advertised on the box or in the manual.
- Things that are likely to go wrong:
 - You'll find a part of the assembly manual incomprehensible.
 - You'll probably strip a screw or two.
 - Stripped screw head (probably Philips head screw)
 - Stripped screw hole in a plastic part
 - You'll most likely build something, discover you did it wrong or forgot a part, so you'll have to disassemble and build it again.
 - You may break a part.

Tips to Get Started

Helicopter Assembly (2)

- Read the whole assembly manual once from start to finish to get a feel for the flow.
- Take inventory of the parts.
 - Don't take parts out of their bags until you need them, but convince yourself that everything is somewhere.
 - In some kits, parts seem to be collected into bags with no discernable system (e.g. parts for assembly step 1 come from bags 2, 5 and 7).
 - Have some small bins or cups on hand to store parts after taking them out of their bags. (Especially small parts have a tendency to disappear when you're not watching them.)
- Don't just go by the pictures in the manual; read the text, too.
 - The assembly pictures don't always tell the whole story, and sometimes pictures may be incorrect or inconsistent.
 - If something just doesn't make sense, take a break and try again later; if that doesn't help, ask someone.

Tips to Get Started

Helicopter Assembly (3)

- If some parts don't go together relatively easily, make sure you're doing the right thing before forcing it.
 - You may have the wrong part; the kit may include parts that look very similar but are not actually identical.
 - You may have something on backwards; sometimes the difference between two sides of a part is subtle.
 - Then again, sometimes parts really do not fit as they should and may need some cutting, sanding, grinding or careful hammering to make things work, but proceed slowly, taking care not to overdo it.
- Be patient, accurate and neat.
 - If you take your time and the resulting helicopter looks good, it's more likely to fly well.
 - If you rush, and the helicopter looks like it was thrown together, it's likely fly poorly and may fall apart during flight.

Tips to Get Started

Helicopter Assembly (4)



Model Helicopter Insights™
RC Helicopter Primer

- Tighten all screws well, except...
 - proceed gently with screws that go into plastic.
 - do not over tighten the main and tail rotor blade bolts, as the blades should be able to pivot around their bolts when medium force is applied.
- Use thread locker.
 - Always use a thread locking compound, for example blue Loctite 242 or 243, when screwing metal into or onto metal.
 - Do not use a thread locker like Loctite 242 with plastic, as it can make the plastic brittle; to secure metal to plastic or plastic to plastic, use something like Loctite 425 or CA glue.
- If a screw goes into a plastic part and you strip the hole...
 - don't do that again (now you know how tight is too tight).
 - with a paper clip or similar, put a little bit of CA glue around the wall of the screw hole and let the glue dry completely before trying again.
- For IC helicopters, always use an engine crank shaft or piston locking tool while attaching the clutch and fan to the engine's crank shaft. *

* A piston locking tool can sometimes damage an engine's piston; crank shaft locks are preferred.

Tips to Get Started

Helicopter Assembly (5)

- The push rod lengths described in the manual may not actually result in a properly set up rotor head.
 - At zero pitch...
 - arms on the rotor head should be horizontally level.
 - arms and links should (for the most part) be 90° relative to each other.
 - Expert help is very beneficial at this point.
- For push rods that are threaded all the way end-to-end, mark the center of each rod with a permanent marker before attaching the ball links.
 - Once each end has a ball link attached, you won't be able to tell how much thread has gone into each link.
 - The center mark will help ensure that you don't inadvertently end up with a link that's only barely hanging on to one end of the rod.
- If your manual shows different link lengths for basic and aerobatic or 3D flight and you have a computer radio, go for the more advanced, 3D setup.
 - Eventually you'll want the advanced setup.
 - While learning, program your transmitter to obtain rotor head behavior that is equivalent to a setup with basic link lengths.

Tips to Get Started

Helicopter Assembly (6)

- Some kits allow you to choose between different parts based on desired flight characteristics.
- Head dampers
 - The head dampers are rubber donuts inside the rotor head assembly.
 - Harder dampers make the helicopter's cyclic pitch control more sensitive.
 - For a trainer setup, choose softer dampers if possible.
- Fly bar
 - The helicopter becomes more responsive as the...
 - fly bar becomes longer.
 - fly bar paddles become lighter.
 - For a trainer setup...
 - use heavier paddles.
 - install fly bar weights.

Tips to Get Started

Helicopter Assembly (7)

- The wiring in a helicopter also requires attention and care:
- Receiver power connectors and servo connectors (e.g. for servo wire extensions) should be secured with something that will prevent the connectors from separating during flight. (Dental floss often works well to tie connectors together.)
- Wires should not be routed around sharp corners that might cause a wire to be cut over time. (A piece of fuel tubing around a wire is one way to provide protection.)
- In an electric helicopter, the wires from the battery to the ESC and the ESC to the motor should be...
 - as short as possible
 - as far away from the receiver and receiver antenna as possible.
- The antenna wire (or wires) coming from the receiver should...
 - not be cut.
 - not be coiled or wound around something (except maybe in a micro or mini helicopter if the antenna wire is longer than the helicopter).
 - not be routed immediately next to metal or carbon parts.
 - have some sort of strain relief to make sure it (or they) can't be accidentally ripped from the receiver.

Tips to Get Started

Helicopter Assembly (8)

- The canopy may need to be trimmed to fit.
 - Mechanical interference between the canopy and moving parts can lead to in-flight failures.
 - Carefully check whether any of the servos or pushrods hit or rub against the canopy.
 - Shift the canopy's position or cut notches or holes as needed to remove the interference.
 - If the canopy touches the muffler, it will most likely melt at the point of contact. Trim the canopy, so it doesn't touch.
- If you break a part, don't worry; you're not the first person who needs a replacement part before his helicopter has ever left the ground.
- To save money on replacement screws, bolts, washers, nuts or bearings, consider sources other than the helicopter manufacturer.



RC Helicopter Primer

Tips to Get Started

Helicopter Selection
Helicopter Assembly
Helicopter Setup and Checkout
First Flights
Simulator Practice

Tips to Get Started

Helicopter Setup: More Than Assembly

- A model helicopter is an intricate machine.
 - After assembly is complete, the helicopter is not yet ready to fly.
 - In addition to the assembly phase, there's a setup and tuning phase.
 - The setup phase partially overlaps the assembly phase, but much of the setup work happens after assembly is complete.
- Helicopter manuals mostly focus on the assembly work; setup is often not covered very well.
- If a helicopter doesn't fly well or at all, the cause of the problem...
 - may be an assembly error (e.g. the thrust bearings in the main blade grips are backwards).
 - is most likely an incorrect setup.

Tips to Get Started

Helicopter Setup: Expert Help

- Some basic setup tips are on the following slides, but...
 - a thorough setup tutorial is beyond the scope of this primer.
 - seek other resources, or get help from an experienced helicopter builder and pilot.
- Some items that strongly benefit from expert help:
 - Setting up the rotor head's control linkages
 - Setting up the gyro and the associated tail pitch control linkage
 - Setting up the throttle linkage and tuning an internal combustion engine
 - Setting the rotor head speed (rotor RPM) and hovering pitch
 - Programming appropriate throttle and pitch curves into the transmitter

Tips to Get Started

Helicopter Setup: Item Summary (1)



Model Helicopter Insights™
RC Helicopter Primer

- Drive system basics *
 - Target rotor head speed (RPM)
 - Engine/motor-to-rotor gear ratio
- Motor, battery, ESC combination for EP helicopters *
 - Motor speed (i.e. kV rating)
 - Battery voltage (i.e. cell count)
 - ESC choice (based on expected currents)
- Control mechanics
 - Servo arm lengths and center positions
 - Push rod / linkage rod lengths
- Control mechanics-related radio programming: servo travel limits
 - Known also as adjustable travel volumes (ATVs) or end points
 - Settings programmed into the transmitter to...
 - maximize range of movement
 - optimize effective servo resolution
 - avoid mechanical binding

* This item needs to be addressed early, during the assembly phase.

Tips to Get Started

Helicopter Setup: Item Summary (2)



Model Helicopter Insights™
RC Helicopter Primer

- Pitch ranges
 - Collective pitch range (i.e. minimum and maximum pitch at mechanical limits)
 - Initial collective pitch and throttle curves (i.e. transmitter programming of pitch and throttle relationship)
 - Cyclic pitch range
- Tail and gyro configuration
 - Tail pitch neutral position
 - Servo travel limits (programmed into gyro)
 - Initial gyro gain
- Fuel mixture for IC helicopters; engine idle
 - Fuel type
 - manufacturer
 - nitro-methane content (e.g. 15%, 20%, 30%)
 - Engine's carburetor settings
 - Engine idle point
- ESC programming for EP helicopters
- Main rotor dynamic adjustments
 - Main rotor blade tracking
 - Actual head speed (possibly multiple speeds for different flight modes)
 - Fine-tuned pitch and throttle curves

Tips to Get Started

Helicopter Setup: Item Summary (3)



Model Helicopter Insights™
RC Helicopter Primer

- Tail rotor dynamic adjustments
 - Fine-tuned tail pitch neutral position (i.e. mechanical tail trim)
 - Fine-tuned gyro gain
- Cyclic control tuning
 - Trims (i.e. radio programming to minimize helicopter drift with no cyclic control input)
 - Expo (i.e. radio programming, exponential stick-to-signal mapping, to adjust cyclic pitch sensitivity)
- Additional radio setup
 - Throttle cut (to shut off the engine)
 - Throttle hold (to hold the engine at idle)
 - Failsafe settings (to minimize danger if radio signal is lost during flight)
- Other (if applicable)
 - Speed governor programming
 - Mixture control programming

Tips to Get Started

Helicopter Setup: Collective Pitch Range



Model Helicopter Insights™
RC Helicopter Primer

- Set up the helicopter mechanics for the maximum collective pitch (i.e. blade angle) range.
- Program the transmitter's pitch curve for a pitch range that's suitable for hover practice and basic flight.
- For example:
 - Mechanical pitch range -12° to $+12^{\circ}$, corresponding to -100% to $+100\%$ collective stick travel at the transmitter.
 - Normal pitch range for new pilots of -2° to $+10^{\circ}$ by programming the transmitter for -17% to $+83\%$ collective pitch.
- Measure the blade angle with a pitch gauge.



Right: Century
pitch gauge

Tips to Get Started

Helicopter Setup: Rotor Head Speed



Model Helicopter Insights™
RC Helicopter Primer

- Approximate main rotor speed ranges for different rotor (or blade) sizes:
 - ≈ 320mm blades (e.g. T-Rex 450): 2400 to 3000 RPM
 - ≈ 430mm blades (e.g. T-Rex 500): 2200 to 2800 RPM
 - ≈ 500 to 600mm blades (30 to 50-size): 1600 to 2100 RPM
 - ≈ 700mm blades (90-size): 1500 to 1900 RPM
- With wood blades, the speed should be at the low end of the range to ensure safe operation; good-quality carbon blades may be run at the high end of the range.
- Higher rotor speeds increase responsiveness (assuming the engine or motor is powerful enough, and the gearing is appropriate), but also burn fuel and drain batteries faster.
- For initial practice flights (e.g. hover practice, basic forward flight), start at the low end of the range regardless of blade type.
- Use a tachometer to measure the rotor speed. (Don't use the tachometer yourself while flying; ask a friend to take the rotor speed reading.)



Right: Model Avionics SkyTach optical helicopter tachometer

Tips to Get Started

Helicopter Setup: IC Engine Tuning (1)

- If you have an internal combustion (IC) powered helicopter, you'll need to tune your glow (or possibly gasoline) engine.
- For a given helicopter, the ideal engine setting depends on...
 - engine type.
 - fuel brand and type.
 - muffler type.
 - glow plug heat level.
 - ambient temperature.
 - other factors.
- A new engine...
 - needs to be tuned differently (i.e. with a slightly richer mixture) than an engine that's been previously broken in.
 - needs to be retuned (leaned) incrementally until it is fully broken in.

Tips to Get Started

Helicopter Setup: IC Engine Tuning (2)



Model Helicopter Insights™
RC Helicopter Primer

- Different engines tend to behave differently.
 - Different makes: for example OS, YS or Thunder Tiger
 - Different models: for example OS 37 SZ-H or OS 50 SX-H Hyper
 - Sometimes even two engines of the exact same type: for example two different Thunder Tiger Redline 53 engines
- There is no one-size-fits-all tuning recipe.
- If possible, get help from someone who...
 - has experience tuning engines.
 - can explain what he (or she) is doing.
 - will teach you what to do.
- Nevertheless, if you can't get help, the following four slides...
 - provide some general, basic tuning tips for glow engines.
 - may help if other resources are lacking.
 - are not guaranteed to produce a perfect result.

Tips to Get Started

Helicopter Setup: IC Engine Tuning (3)

- 30 to 50-size engines tend to have two mixture control screws:
 - Idle or low-end screw: affects idle mixture, possibly up to 50% throttle.
 - High-end screw (sometimes called needle valve): affects high-end operation, maybe 25% to 100% throttle.
- Start with both screws at the factory recommended settings.
- For a brand new engine or when in doubt...
 - richen it beyond the factory setting by turning the high-end screw up to half a turn counter-clockwise.
 - fly it rich for several tanks (about half a gallon to one gallon of fuel), then incrementally lean it to a fully tuned setting.
 - fly gently; don't execute abrupt, high-power maneuvers until fully tuned.
- The mixture control screws of different engines tend to work the same way:
 - To richen the mixture, turn a mixture control screw counter-clockwise.
 - To lean it, turn the screw clockwise.

Tips to Get Started

Helicopter Setup: IC Engine Tuning (4)



Low-End Mixture Control Screw

High-End Mixture Control Valve

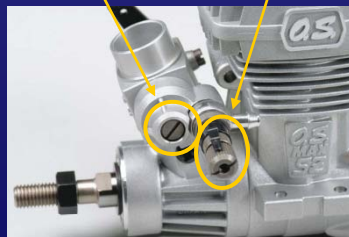

Above: OS 37 SZ- H Ring engine



High-End Mixture Control Valve

Low-End Mixture Control Screw

Above: Thunder Tiger Redline 53 engine

Right: OS 50 SX-H Hyper engine



Tips to Get Started

Helicopter Setup: IC Engine Tuning (5)



Model Helicopter Insights™
RC Helicopter Primer

- Attach the glow plug heater (a.k.a. glow driver), start the engine, and let it idle.
- If the engine's idle speed drops or the engine stops once you remove the glow driver, the engine is idling too rich. → Lean the low-end screw by one eighth of a turn.
- Repeat this exercise until the engine maintains its idle speed.
- While the engine is idling, pinch off the fuel line feeding into the engine.
- If, within a second or two, the engine's idle speed rises or the engine stops, the engine is idling too lean. → Richen the low end screw by one eighth of a turn.
- Repeat this exercise until the engine does not speed up too soon.

Tips to Get Started

Helicopter Setup: IC Engine Tuning (6)



Model Helicopter Insights™
RC Helicopter Primer

- Fly the helicopter, holding it in a hover for 20 to 30 seconds.
- Land the helicopter and carefully touch the engine's back plate.
 - Be careful while approaching a helicopter with a spinning rotor.
 - Even a slowly moving rotor blade can cause injury.
 - Don't check the engine until the rotor has stopped.
- If the back plate...
 - is very hot to the touch (i.e. nearly burns your finger), the engine is too lean. → Richen the high-end screw by two clicks.
 - is barely warm, the engine is too rich. → Lean the high-end screw by one or two clicks.
- Repeat this exercise until the back plate feels moderately hot without burning your finger.



Back
Plate

Tips to Get Started

Helicopter Setup: IC Engine Tuning (7)

- The finger-test method...
 - is very subjective and not very precise.
 - is affected by engine size.
 - Smaller engines (e.g. 30-size) will feel a bit hotter.
 - Larger engines (e.g. 90-size) should feel cooler.
- Alternatively, use a thermometer to measure the temperature of the cylinder head.
 - The head temperature of a (slightly conservatively) tuned engine is typically around 100°C or 210F.
 - If the actual temperature is...
 - higher, the engine is too lean. → Richen the high-end screw by two clicks.
 - lower, the engine may be too rich. → Lean the high-end screw by one or two clicks.
 - Consider that the engine will have cooled some since the helicopter has landed.



Above: infra-red thermometer

Cylinder Head

Tips to Get Started

Helicopter Setup: IC Engine Tuning (8)



Model Helicopter Insights™
RC Helicopter Primer

- Engine temperature may also be monitored in flight with an on-board temperature gauge.
- Such a temperature gauge...
 - employs a sensor that is looped around the engine's cylinder head.
 - measures and displays...
 - current temperature.
 - maximum temperature
 - minimum temperature.
- The maximum temperature feature is perfect for capturing the highest temperature during flight for tuning purposes.



Above: Traxxas digital temperature gauge with attached sensor loop (top), Venom digital temperature gauge with sensor loop shown separately (bottom)

Tips to Get Started

Helicopter Checkout (1)

- If at all possible, ask an experienced pilot or flight instructor to inspect (and if needed adjust) your newly built model before its first flight.
- An inspection helps ensure safe operation of the helicopter.
 - Build or setup problems can make a helicopter crash prone.
 - A helicopter accident could cause severe injury or property damage.
- The expert or instructor can fill gaps left by the assembly instructions.
 - Settings documented in the manual may have been only starting points; settings may need to be modified based on, for example, the installed engine and servos.
 - Programming the transmitter for the first time can be a challenge.
- Look for an expert helper who not only fixes things with you but explains what he's doing.
- Different experts may have different approaches, so if possible stick with one helper for a while, so you're not confused by these different approaches.

Tips to Get Started

Helicopter Checkout (2)

- Your expert can also test fly and trim the helicopter for you.
 - A properly trimmed helicopter will be easier to hover and fly.
 - You may find it comforting to see that your helicopter can fly before you take control for the first time.
- Some things are difficult (and possibly unsafe) to do alone, especially for a new pilot.
 - Blade tracking adjustments
 - Head speed measurements and adjustments
- Note that an inspection by an experienced pilot is not a guarantee that everything is perfect.
 - If it wasn't built properly, the helicopter may have hidden or dormant flaws that could lead to a crash, even while your expert or instructor is flying the model.
 - The inspection is not a substitute for care during the build process.

Tips to Get Started

Helicopter Checkout (3)

- Do not be discouraged if your helicopter doesn't fly well or doesn't fly at all on the first day.
- A newly built helicopter may need to go through several cycles of taking test flights and tweaking something.
- If something isn't working right, there are often multiple potential causes, none of which may be obvious.
 - One common issue is tail instability or side-to-side oscillation (a.k.a. tail wag); it may be due to improper gyro setup, a problem with the tail pitch control linkage or an out-of-tune engine (or possible other causes not listed here).
 - Interplay exists among some settings, such that if one setting is changed, some others may need to be adjusted, too. (For example, if the engine mixture is changed, the pitch and throttle curves may need to be changed to maintain the same hover point.)
- Patience will yield a well-flying machine.



RC Helicopter Primer

Tips to Get Started

Helicopter Selection
Helicopter Assembly
Helicopter Setup and Checkout
First Flights
Simulator Practice

Tips to Get Started

First Flights



Model Helicopter Insights™
RC Helicopter Primer

- The following slides...
 - outline one possible approach for learning basic RC helicopter flying skills.
 - provide a high-level guide through a progression of fundamental skills.
- This material...
 - does not provide comprehensive flight instruction.
 - is not intended to replace a flight instructor.
- Use this guide in conjunction with other sources of flight instruction.
 - If you're flying at a club that offers flight training, consider working with an instructor.
 - Clubs often offer such training at no charge beyond the club membership fee.
 - Different instructors will have different styles, so if your first instructor isn't working for you, try a different one.
 - Follow a route that feels comfortable and rewarding to you.
- If possible, practice all new skills on a simulator before trying them with your actual model.

Tips to Get Started

First Flights: Safety

- Respect your helicopter and be safe!
- Remember that...
 - rotor blades (main rotor and tail rotor) spin at high speeds and can potentially cause serious injury.
 - an out-of-control helicopter can be very dangerous.
- Don't fly too close to yourself.
- Don't fly close to spectators.
- If you fly in a public park, be aware that some people (especially children) may abruptly walk up to you or the helicopter.
 - People often don't appreciate how much damage spinning rotor blades can do!
 - Keep a safe distance from others.
 - Land when people approach.

Tips to Get Started

First Flights: Safety Checklist (1)

- At the beginning of every day of flying, complete a set of pre-flight checks.
- A basic pre-flight procedure includes the following steps:
 - Ensure that all batteries are charged, and perform a load test on the receiver battery.
 - Check that all control links (i.e. at the main rotor head, for the tail rotor, for the engine throttle) are secure by gently pulling on each with your fingers; they should not come off.
 - Visually inspect screws and bolts, and make sure that no screws are loose or backing out.
 - Inspect all electrical wires and connectors (power, servos to receiver, servo extensions, etc.); make sure all are intact and firmly connected.
 - Unless you're using a spread spectrum radio...
 - make sure that your radio channel is unused.
 - at a club, check out the proper frequency pin.
 - Test the radio link between your transmitter and your model, and confirm that it is working properly.

Tips to Get Started

First Flights: Safety Checklist (2)

- To turn your model on safely and to test the radio link:
 - Always turn the transmitter on first.
 - Check that the correct aircraft model is selected in the transmitter.
 - Move all sticks and switches to their inactive positions, so that the helicopter's engine or motor will power up in its idle state (as opposed to starting abruptly at high speed).
 - Turn on the model's electronics.
 - Turn on the receiver.
 - For an electric helicopter where the receiver is powered by the motor battery through a BEC...
 - activate throttle hold (one of the transmitter switches), so that the motor won't start when you move the collective stick.
 - plug in the motor battery.
 - Verify that the controls behave as expected.
 - Moving the cyclic stick tilts the swash plate in the expected directions.
 - The collective control causes the swash plate to rise and fall.
 - The rudder control properly actuates the tail rotor.
 - Complete a range check. (Your transmitter manual should provide more details on this operation.)
 - Return all transmitter sticks and switches to their inactive positions.
- Consider putting this checklist (or perhaps a checklist provided by your club) on a piece of paper and actually checking items off each time until you've become used to the procedure.

Tips to Get Started

First Flights: Training Gear



Model Helicopter Insights™
RC Helicopter Primer

- At the beginning, equip your helicopter with an extended landing or training gear.
- An untrained pilot can easily tip a helicopter over, resulting in a crash without ever getting off the ground.
 - With a training gear, a helicopter is much harder to tip.
 - The training gear will also absorb some of the impact of a hard landing.
- Use the training gear until you can take off and land smoothly.



Above: EasyFly50 trainer helicopter in Phoenix simulator

Tips to Get Started

First Flights: Hovering

- Your first skill to master: hovering
 - Hovering means to raise the helicopter off the ground and then maintain its altitude and position in a smooth, stable fashion.
 - Helicopter flights tend to start and end in a hover.
 - Hovering practice...
 - builds basic but critical collective and cyclic pitch control skills.
 - develops a sense of the helicopter's orientation.
- Once you have solid hovering and good cyclic control skills, you're ready to start forward flight and turns.
- Note: The following slides assume a Mode 2 transmitter.
 - Collective and rudder control on the left stick.
 - Cyclic control (elevator and aileron) on the right stick.

Tips to Get Started

First Flights: Tail-In Hovering (1)

- First learn tail-in hovering (i.e. the helicopter's tail is pointing towards you).
- During a tail-in hover, the helicopter's movements will match your movements of the right control stick.
 - Pushing the right stick forward causes the helicopter to move forward and away from you, right stick right moves the helicopter to the right, and so on.
 - New pilots tend to provide necessary control inputs late and then overcorrect, so the helicopter ends up moving around a lot.
 - The goal is to develop the proper reflexes, so that hovering does not require conscious thought.

Tips to Get Started

First Flights: Tail-In Hovering (2)



Model Helicopter Insights™
RC Helicopter Primer

- Start by getting a feel for the helicopter's response to collective and throttle control inputs.
 - Slowly push the left stick up.
 - Gently increase the collective pitch (and rotor speed) until the helicopter starts to get light on its landing gear.
 - Slowly bring the left stick down again and settle the helicopter into its original spot.
- Repeat this process several times until it's comfortable; don't rush it.



Above: EasyFly50 trainer helicopter in Phoenix simulator

Tips to Get Started

First Flights: Tail-In Hovering (3)



Model Helicopter Insights™
RC Helicopter Primer

- Continue by advancing the left stick further and lifting the helicopter only a few inches off the ground.
 - Lift off gently to approximately 6 inches (15 centimeters).
 - Avoid drifting from the original position.
 - Use the right stick (i.e. the cyclic pitch control) to maintain the helicopter's position.
 - A little bit of right cyclic (i.e. right stick to the right) will most likely be required.
 - Land again gently.
- Once these short hops feel comfortable, raise the helicopter higher step by step (up to maybe 10 or 20 feet, or 3 to 6 meters).



Above: EasyFly50 trainer helicopter in Phoenix simulator

Tips to Get Started

First Flights: Tail-In Hovering (4)



Model Helicopter Insights™
RC Helicopter Primer

- When the helicopter is starting to take off, it will probably start sliding to one side (most likely to the left).
 - Assuming a clockwise rotating main rotor, a tendency to move left comes from the thrust produced by the tail rotor, so a hovering helicopter needs a bit of right cyclic to balance that thrust.
 - If the helicopter consistently tends to move in a direction other than left, it may not be trimmed properly. If necessary, get help to trim the helicopter.
 - If the helicopter is zipping off in random directions, you may be unintentionally applying cyclic control inputs.
 - If possible, program your transmitter to reduce the sensitivity of the right stick around its center.
 - Look for the “expo” function of your transmitter.
- Because some cyclic pitch is required to compensate for tail rotor thrust, helicopters naturally hover with a slight lean to the side (given a clockwise turning main rotor, a lean to the right).
- Holding the helicopter in a steady hover is likely to require continuous cyclic control inputs.
 - The required cyclic control inputs are usually quite subtle.
 - You should not have to move the right stick very far away from its center.

Tips to Get Started

First Flights: Tail-In Hovering (5)



Model Helicopter Insights™
RC Helicopter Primer

- Maintain a safe minimum distance from your helicopter.
 - About 30 feet (10 meters) for a 30- or 50-size machine.
 - About 10 feet (3 meters) for a micro helicopter.
- For now, always keep the helicopter's tail pointing towards you (perhaps 10 to 20° off to either side).
 - Throttling up too fast may cause the helicopter to turn before take-off (probably nose left or counter clockwise); be gentle.
 - Especially with a heading-hold gyro, the tail should hold well once the helicopter is in flight.
 - If necessary, provide gentle rudder inputs (left stick right or left) to keep the tail pointing towards you (within 10 to 20°).

Tips to Get Started

First Flights: Tail-In Hovering (6)

- While hovering tail-in...
 - do not keep the helicopter's tail pointing directly at you.
 - for safety reasons (e.g. in case a tail blade comes loose), keep the tail slightly (10 to 20°) off to one side (in this example, slightly to the right).
- Also keep the helicopter at a safe distance, at least several (about seven) rotor diameters away from you.



Above: EasyFly50 trainer helicopter in Phoenix simulator

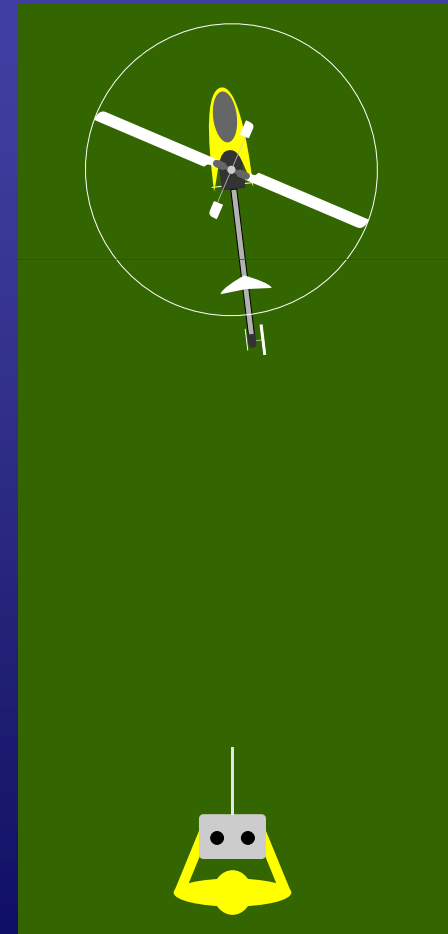

Tips to Get Started

First Flights: Tail-In Hovering (7)



Model Helicopter Insights™
RC Helicopter Primer

- At first, you may want to avoid windy days to simplify initial flights, but eventually you'll need some practice hovering in mildly gusty conditions.
 - In windy conditions, minimize the impact of the wind by hovering with the helicopter's nose pointing into the wind (upwind).
 - Wind makes a helicopter's rotor more efficient, so it generates lift more easily.
 - Changes in wind strength will cause the helicopter to rise or descend.
 - You will need to apply frequent collective control inputs to hold the helicopter at a steady altitude.
- If the helicopter gets too close or gets away from you, land it, walk over, pick it up and set it back to its starting position.
- Initial hovering practice can be quite stressful, so take breaks whenever you get tired.
- Once take-offs, tail-in hovering and landings are smooth and feel comfortable, take the training gear off and try without.

Tips to Get Started

First Flights: Tail-In Side-to-Side (1)



Model Helicopter Insights™
RC Helicopter Primer

- As a progression from initial tail-in hovering, practice flying side to side.
 - Lift the helicopter into a tail-in hover (maybe 10 feet high).
 - Provide some right cyclic to slowly move to the right.
 - After a short distance, provide left cyclic to stop the sideways motion, then hold the helicopter in a hover.
 - Now move to the left in the same way, again stopping in a hover.
 - Continue the right/left/right/left motion, and eventually return to the center to land the helicopter.
- For this maneuver...
 - the necessary cyclic control inputs will be relatively light.
 - you shouldn't have to move the right stick very much.

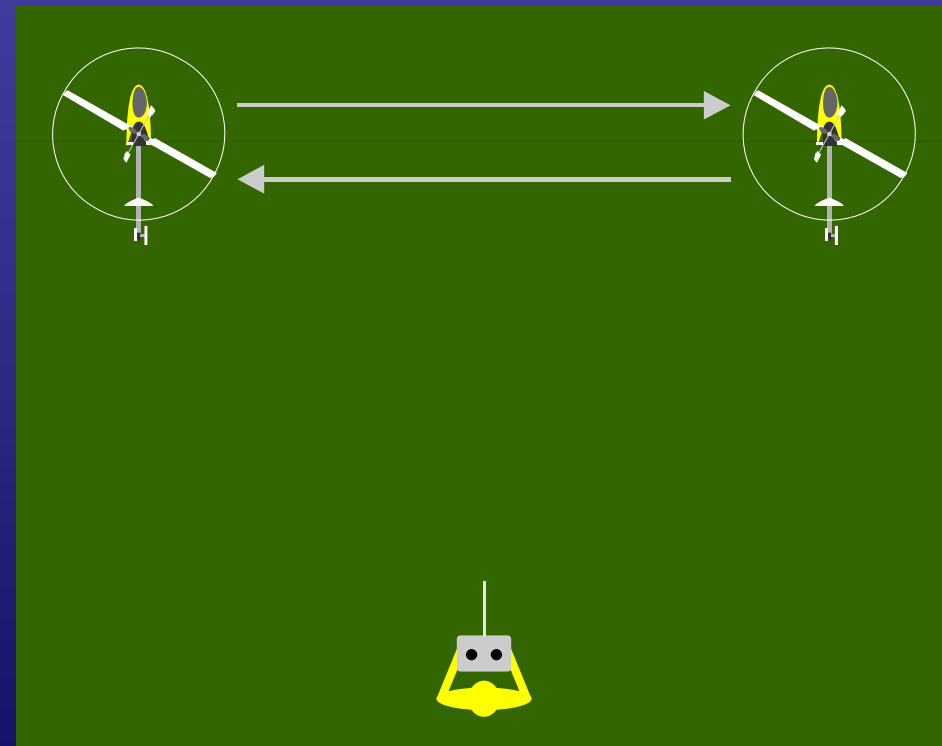

Tips to Get Started

First Flights: Tail-In Side-to-Side (2)



Model Helicopter Insights™
RC Helicopter Primer

- When you fly the helicopter...
 - to the side, your view of it will change.
 - This exercise helps prepare you for side-in hovering.
 - As you get more comfortable, you can increase the side-to-side distance.
 - it will tend to change altitude when you enter and exit the hover points on the sides, so use the collective pitch control to compensate.
- Practice until you can...
 - maintain a fixed altitude throughout the maneuver.
 - start and stop at each side crisply but smoothly.

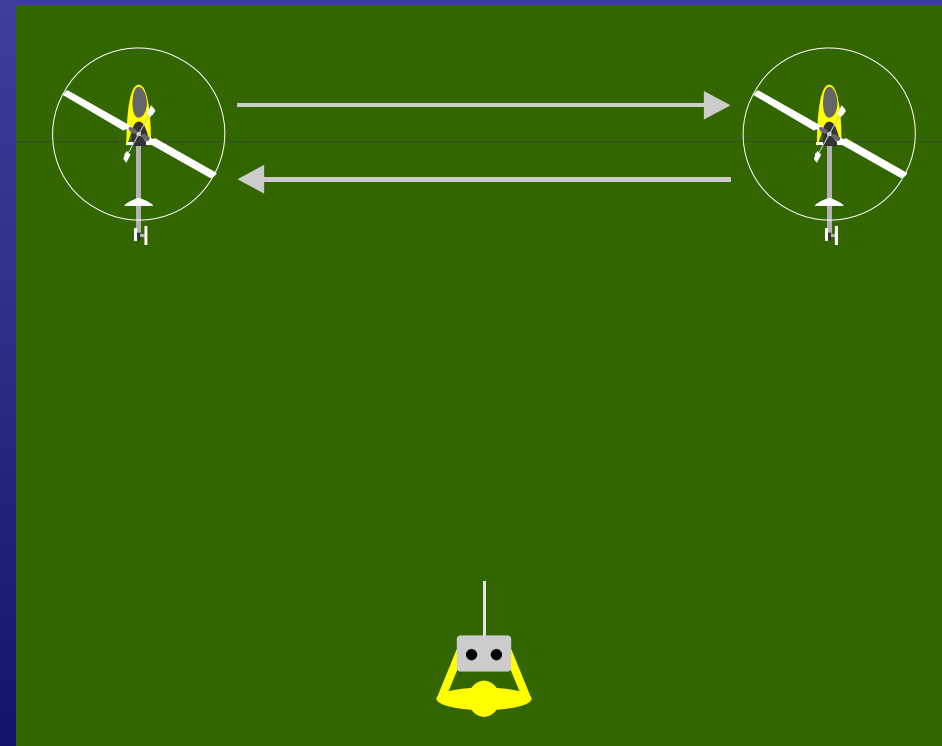

Tips to Get Started

First Flights: Side-In Hovering (1)



Model Helicopter Insights™
RC Helicopter Primer

- After you've become comfortable with tail-in hovering and side-to-side movement, turn the helicopter by 45° and later 90° in either direction and learn hovering right and left side in.
 - Side-in hovering tends to be confusing at first because the right stick will now appear to behave differently.
 - Assuming a right-side-in hover (i.e. you're looking at the helicopter's right side and its nose is pointing right), if you push the right stick forward, the helicopter still goes forward, but helicopter-forward is now to your right.
 - You need to expand the reflexes you learned during tail-in hovering; imagine yourself in the helicopter's cockpit.
 - Hover at least 20 feet high, so that you have some altitude to recover from a moment of confusion.
- Later, for an added challenge and to improve your sense of the controls, try...
 - gentle side-to-side forward flight.
 - hovering by moving the right stick only diagonally.

Tips to Get Started

First Flights: Side-In Hovering (2)

- 45° hover as a step towards side-in hovering...
- Use the rudder control (left stick right/left) to slowly and gently turn the helicopter from the tail-in position to the new position.
- If you get disoriented, quickly turn the helicopter back to the tail-in position.



Hover at a higher altitude than shown in these pictures.

Above: Raptor 30 helicopter in Reflex XTR simulator

Tips to Get Started

First Flights: Side-In Hovering (3)



Model Helicopter Insights™
RC Helicopter Primer

- Complete side-in hover...
- As before, turn into it gently and turn back quickly if confusion ensues.
- New pilots may suffer from a perspective flip, where all of a sudden...
 - it's not clear whether the helicopter is leaning to its right or left.
 - they provide the wrong control input and may cause a crash.



Hover at a higher altitude than shown in these pictures.

Above: Raptor 30 helicopter in Reflex XTR simulator

Tips to Get Started

First Flights: First Forward Flight



Model Helicopter Insights™
RC Helicopter Primer

- Next, try gentle forward flight by modifying the earlier side-to-side exercise.
 - Fly left to right and right to left in the forward direction.
 - At each end, transition to a hover and turn the helicopter around.
 - Turn counterclockwise on the right.
 - Turn clockwise on the left.
- As with the first side-to-side exercise...
 - your view or perspective of the helicopter will change as it moves.
 - slowly increase the length of flight and distance between stopping points as you get more comfortable.

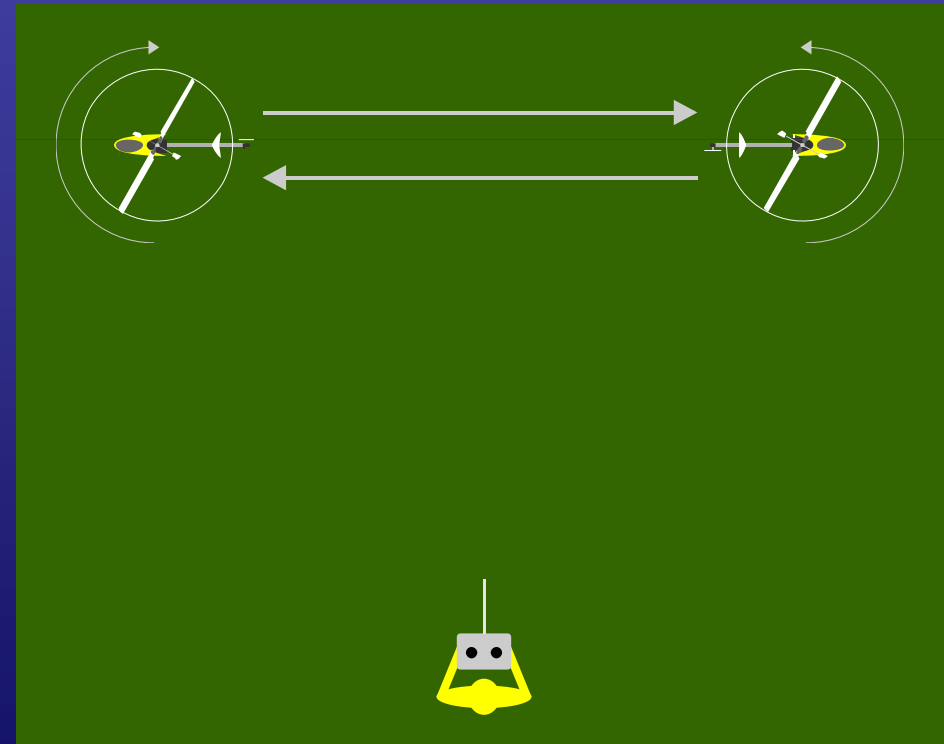

Tips to Get Started

First Flights: 45° Control Exercise

- A new pilot will naturally tend to control the helicopter by moving the right stick only forward/backward or right/left.
- Expand your skills, by forcing yourself to hover tail and side-in by moving the right stick only along the diagonals.
- This exercise may help you prepare for slow pirouettes and turns during forward flight.



Above: Futaba 7C radio control transmitter

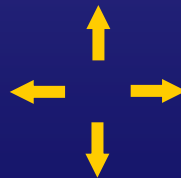

Above: Futaba 7C radio control transmitter

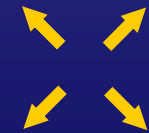

Tips to Get Started

First Flights: Tail-In Triangle

- For more practice with the cyclic pitch control, fly in a triangular pattern while maintaining a tail-in orientation.
 - As with the earlier side-to-side exercises...
 - maintain a fixed altitude throughout the maneuver.
 - make smooth but crisp transitions at the corners of the triangle.
 - Try the triangle in both directions.
 - The picture on the right shows a counterclockwise path.
 - Reverse the direction for a clockwise path.
- Later, after having practiced nose-in hovering, consider flying the triangle while maintaining the nose-in orientation.

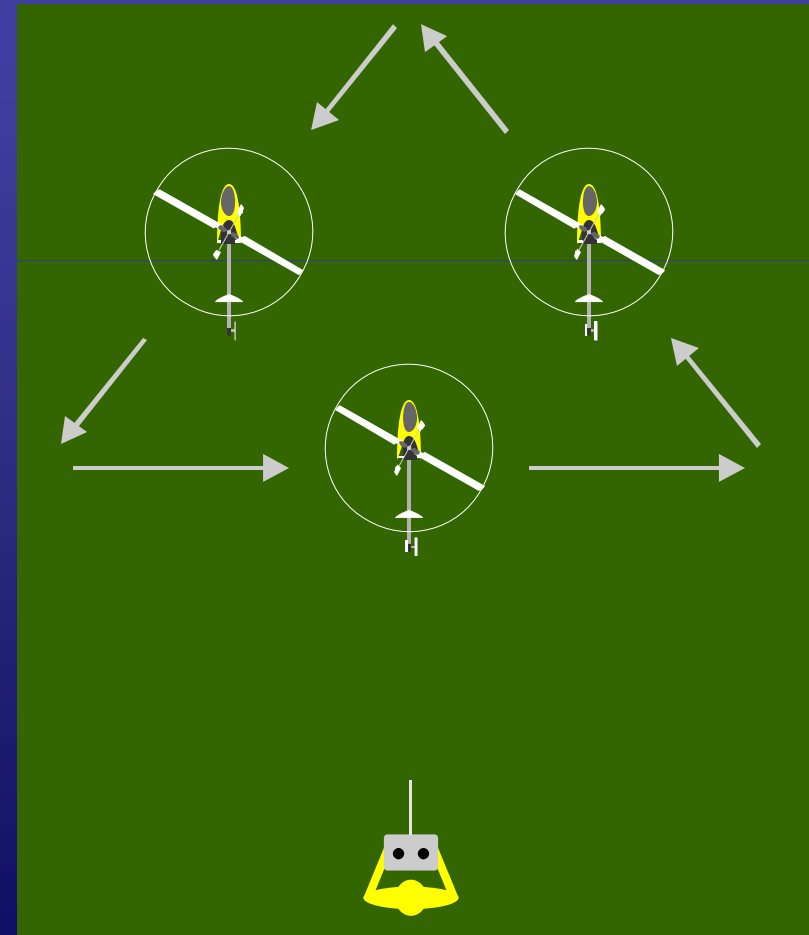

Tips to Get Started

First Flights: Nose-In Hovering (1)



Model Helicopter Insights™
RC Helicopter Primer

- After hovering side-in, progress to a nose-in hover.
 - This orientation is very challenging because the behavior of the right stick now appears to be totally reversed relative to a tail-in hover.
 - Turning the helicopter from a tail or side-in position to the nose-in position may feel terrifying.
 - Some people benefit from temporarily putting the training gear back on and lifting off from the nose-in position.
- Nose-in hovering is especially difficult for many people; take your time.
- Some people choose to skip nose-in hovering and immediately move on to forward flight with turns.
 - They may simply avoid the nose-in position during flight (but this strategy may be risky, as they may get confused and crash in case they end up with a nose-in orientation unexpectedly).
 - They may use forward flight to gently sneak up on nose-in hovering.

Tips to Get Started

First Flights: Nose-In Hovering (2)



Model Helicopter Insights™
RC Helicopter Primer

- One approach to practicing nose-in hovering with your real helicopter (assuming you're comfortable with the nose-in orientation on the simulator)...
- Just like with initial tail-in hovering, use the training gear, lift off gently, increasing altitude one step at a time.



Above: EasyFly50 trainer helicopter in Phoenix simulator.

Tips to Get Started

First Flights: Nose-In Hovering (3)



Model Helicopter Insights™
RC Helicopter Primer

- Direct nose-in hover (with no training gear) and 45° from nose-in...
- Once basic nose-in hovering works ok, try hovering in positions 45° from nose-in.
 - Even though this position is only a small change from direct nose-in, it may be quite challenging.
 - For extra complexity, hold the different hover positions by moving the cyclic stick only along the diagonals.
 - These exercises are good preparation for slow pirouettes.



Above: Raptor 30 helicopter in Reflex XTR simulator



Hover at a higher altitude than shown in these pictures.

Tips to Get Started

First Flights: Figure Eights (1)

- Next, progress to smooth forward flight and turns with well-controlled figure eights.
 - First, fly figure eights, so the helicopter heads away from you during the turns.
 - Later, reverse the figure eight, so the turns are towards you.
 - This figure eight is more challenging than the first.
 - During this maneuver, the helicopter transitions through the nose-in orientation.
- Over time, gently increase the speed of flight.

Tips to Get Started

First Flights: Figure Eights (2)

Initial Figure Eights:

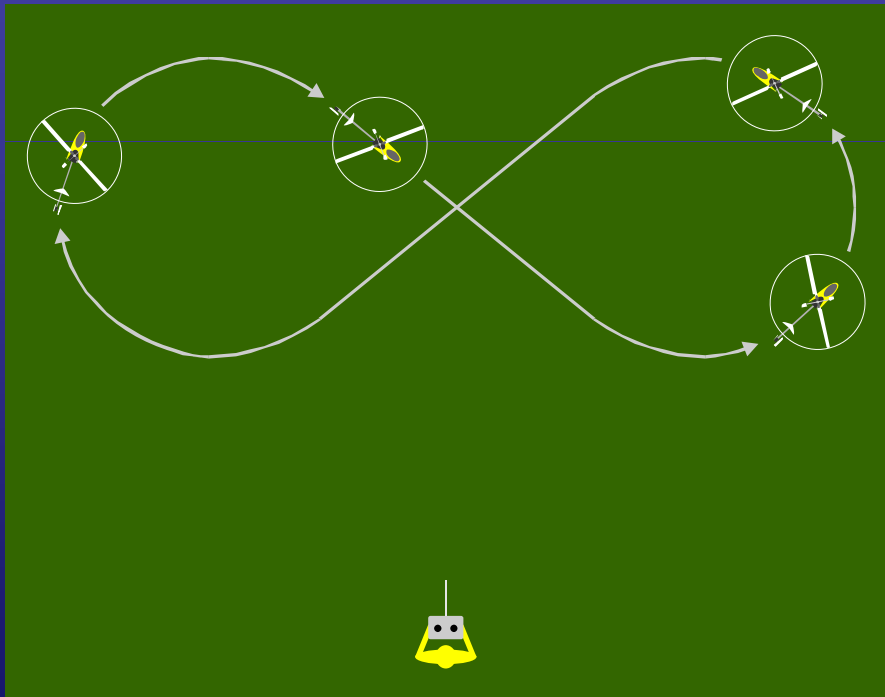

More Advanced Figure Eights:

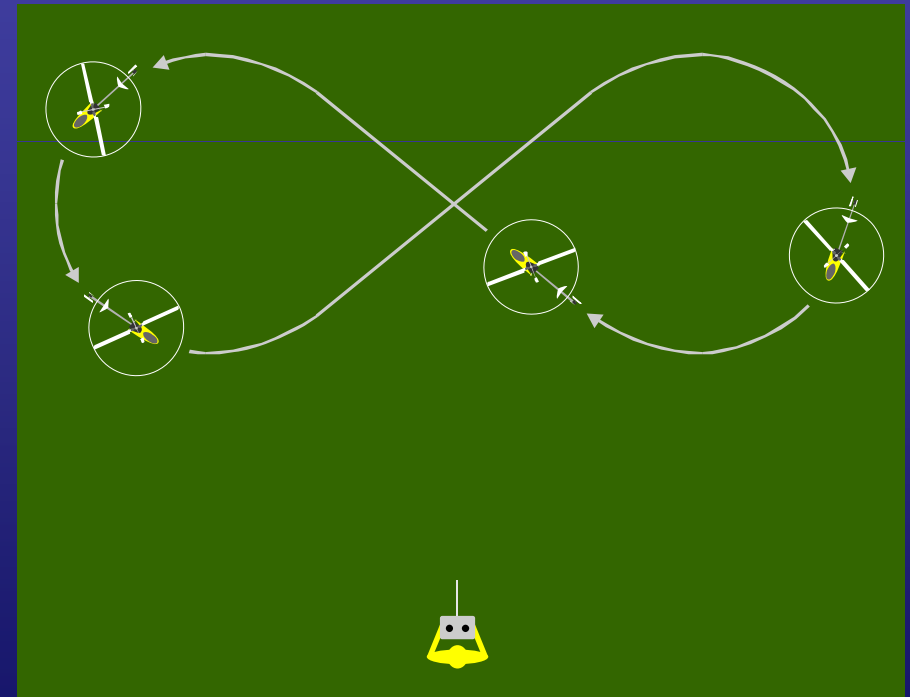

Tips to Get Started

First Flights: Slow Pirouettes

- After nose-in hovering and forward figure-eights work fine, practice slow (five to ten second) pirouettes: use the rudder control to turn the helicopter 360° while maintaining a steady hover.
 - Hover at an altitude of 30 to 40 feet (approximately 10 meters), so that you have time to recover if confusion ensues and a pirouette falls apart.
 - If moving through the 135°-from-tail-in position (i.e. a quarter turn or 45° before nose-in) is troublesome, practice hovering there by moving the right stick only diagonally.
 - Be sure to practice clockwise as well as counterclockwise pirouettes.
- Slow pirouettes can be difficult; give yourself time to master this skill.

Tips to Get Started

First Flights: Don't Panic

- Always watch the helicopter, but do not rely too heavily on what you see; your eyes will trick you (e.g. perspective flip).
- Use your mind to keep track of your helicopter's orientation, and trust your sense of where you know the helicopter is.
- When confusion sets in, don't panic.
 - Some crashes occur because new pilots get disoriented and then provide too much of the wrong control input.
 - Give the helicopter some small control commands (e.g. a gentle wiggle of the right/left cyclic) to see how it responds and thereby recover your sense of its orientation.

Tips to Get Started

First Flights: Next Steps

- The flight exercises outlined in the previous slides are only the beginning (and only one possible beginning).
- After you're comfortable with hovering and basic forward flight, many routes for advancement exist, such as:
 - Auto-rotations
 - Stall turns
 - Loops, rolls and flips
 - Inverted hovering and inverted flight
 - Backwards flight
 - Aggressive aerobatics (i.e. 3D maneuvers).
- Have fun and be safe!





RC Helicopter Primer

Tips to Get Started

Helicopter Selection
Helicopter Assembly
Helicopter Setup and Checkout
First Flights
Simulator Practice

Tips to Get Started

Simulator Practice (1)

- Practice new skills on a simulator until you feel reasonably comfortable.
 - Don't worry about whether your simulator includes the exact model helicopter you have; select a simulated model that is close.
 - You will gain valuable skills on your simulator, although you're still likely to get high blood pressure and sweaty palms when you first apply those skills to your real model.
- Some simulators model helicopters better than others. For example, if simulated wind gusts don't make the helicopter bob up and down, the simulation is not that accurate (but may be good enough).
- Even an imperfect simulator can be excellent crash insurance.

Tips to Get Started

Simulator Practice (2)

- Don't get discouraged if your real model appears harder to fly than the simulator; pilots often do much better on the simulator than in reality.
- Reality will be different from simulation for several reasons, such as...
 - Fear factor: While crashing a simulated model costs nothing, a crash of a real model will at best cost money and repair time and at worst do serious damage to other objects or people.
 - Trust in the aircraft: The simulated aircraft is (most likely) free of setup problems and potential malfunctions, but the real aircraft may not be that reliable (or at least may not feel that way).
 - Weather: Windy conditions can make flights more difficult, and even after simulator practice with simulated wind, actually feeling the wind on your face may change the experience.

Tips to Get Started

Simulator Practice (3)

- Reality will be different from simulation for several reasons, such as (cont)...
 - Glare: Compared to the simulator screen, an actual daytime sky with glare from the sun or bright, diffuse light from clouds may make it hard to see the model.
 - Field of vision: On the simulator, the image automatically pans to keep the model in view, but in reality you'll have to turn your head and the model may appear to be getting out of control faster than on the simulator.
 - Distractions: In reality, there may be other aircraft buzzing around or people may be watching or talking.
 - Flight physics: While today's advanced simulators offer good flight physics models, they are just models. Reality, on the other hand, is guaranteed to be 100% real.
- Even with their limitations, simulators are excellent learning tools.

Tips to Get Started

Simulator Practice (4)

- For a simulator to be useful, avoid treating it like a game.
 - A crash on the simulator only costs a press of the reset key, but...
 - always take off and land in a controlled manner.
 - fight to maintain (or if necessary regain) control of your simulated model.
 - pretend a crash would cost at least \$100 and a few days of repair time.
 - Don't fly too close to the simulator's pilot or camera position; learn to fly at a distance.
 - Minimize the amount of panning the simulator's camera has to do to keep up with the model; strive to fly in a limited, predefined space.
 - Turn on wind modeling in your simulator (maybe 5 to 10 mile/hour wind with mild gusts); the air in the real world is often not still.
 - If you're going to crash, get in the habit of engaging throttle-hold mode before hitting the ground; doing so will minimize damage to the helicopter.
- Some simulators also offer...
 - special trainer modes (e.g. for hover training).
 - tutorials for various types of flight and special maneuvers.



RC Helicopter Primer

End of Tips to Get Started

Helicopter Selection
Helicopter Assembly
Helicopter Setup and Checkout
First Flights
Simulator Practice



RC Helicopter Primer Additional Resources

Additional Resources

Organizations and Discussion Sites



Model Helicopter Insights™
RC Helicopter Primer

- Academy of Model Aeronautics:
<http://www.modelaircraft.org/>
- International RC Helicopter Association:
<http://www.ircha.org/>
- Some internet discussion sites:
 - <http://www.runryder.com/>
 - <http://www.helifreak.com/>
 - <http://www.rchelispot.com/>
 - <http://www.rcheliaddict.co.uk/>
 - <http://www.rcgroups.com/>
 - <http://www.rcuniverse.com/forum/>
- Some on-line, helicopter-specific resources:
 - The Electric Helicopter Beginner's Guide
<http://www.swashplate.co.uk/html/ehbg.html>
 - <http://www.ronlund.com/getting.htm>
 - <http://www.heliproz.com/novadvice.html>
 - <http://www.rchelicoptweb.com/>
 - <http://www.raptortechnique.com/>
 - <http://www.trextuning.com/>
 - <http://www.50-tuning.com/>
 - <http://www.helifever.com/>
 - <http://www.helipedia.com/>
- Additional resources:
 - <http://www.animatedengines.com/>

Additional Resources

Books



Model Helicopter Insights™
RC Helicopter Primer

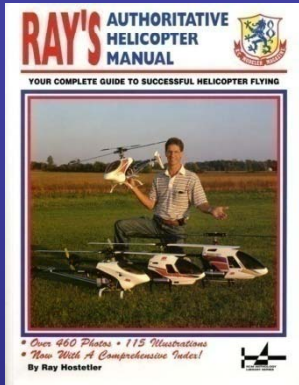

*Ray's Authoritative
Helicopter Manual*

Ray Hostetler

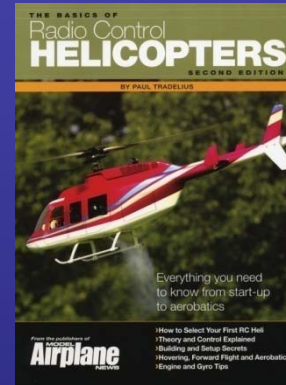

*The Basics of Radio
Control Helicopters*

Paul Tradelius



*2-Stroke Glow Engines
for R/C Aircraft*

David Gierke

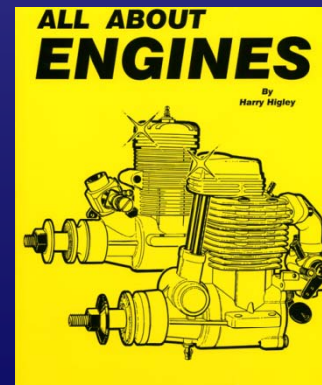

All About Engines

Harry Higley



RC Helicopter Primer

End of Additional Resources



Model Helicopter Insights™

End of RC Helicopter Primer

Good Luck
and
Have Fun

Copyright © 2006-2009 Wolf Witt
All Rights Reserved

Photographic images (e.g. product photos) acquired from the world wide web unless otherwise noted. All text, tables, drawings diagrams, simulator screen captures and document scans by Wolf Witt unless otherwise noted.

The right to reproduce this material for non-commercial purposes is hereby granted, provided it is reproduced in unedited form, in its entirety, with all credit and copyright notices intact. This material may not be used for commercial purposes without express written permission from the author.